

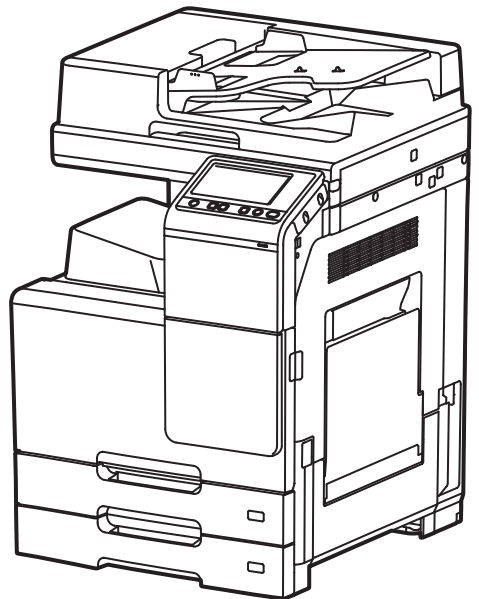

D330E Series

Quick Start Guide

- Before using this product, please read the user's manual and keep it well.



Safety Instructions

Be sure to observe the following instructions when using the device.

 **Warning :** Failure to observe the instructions may lead to death or serious injury.

- Directly plug the power cord in the receptacle on the wall. Do not use extension cord.
- If the power cable or plug is worn or damaged, pull out the power plug.
- In order to prevent electric shock or exposure to laser radiation (in case of a laser device), do not remove the cover or screw which is not stated in the user manual.
- Turn off power and pull out the power plug in the following situations;
 - If something is spilled on the device
 - When considering the service or repair request on the device
 - When the device cover is damaged
- In case of a device using toner, do not burn the spilled toner or the waste toner. If a toner particle is exposed to the screen, it may be ignited.
- In case of disposal, contact our company's seller use the proper collection place.
- In case of not using the product for a long time or when leaving the office after business hours, turn off the power. Otherwise, it may cause an abrupt fire accident.

 **Caution :** Failure to observe the instructions may cause serious and slight injuries or property damages.

- Protect the device from a humid or wet condition including rain, snow, and so on.
- Pull the power cord off from the receptacle on the wall before moving the device. Be careful not to damage the power cord while the device is being moved.
- Be sure not to pull the cable when pulling the power cord off from the wall receptacle. Be sure to pull out with the plug.
- Be sure not to have a clip, a staple, or another small metal object fell inside the device.
- Be careful of a safety accident when servicing the inside of the device including the removal of paper jam, cleaning of the inside of the device, and so on.
- In case of the device using toner, keep the toner and the toner container in the place where cannot be reached by a child.
- Do not dispose of the device or consumables in the place treating household waste. In case of disposal, contact our company's seller use the proper collection place.
- The inside of the device may be very hot. Do not touch the part with the "Careful! Very Hot!" label attached or the spot around the part. Otherwise, it may cause burn.
- Our company's product conforms to the quality standards and performance. It is recommended to use only the genuine parts possibly purchased from an authorized distributor.

Before Using the Product

Thank you for purchasing our product.

This user manual is intended for first-time user of this MFP as well as MFP administrators.

This manual explains functions and operation procedures of MFP, user tips and important warnings, maintenance tips, and simple troubleshooting.

Read this manual carefully to fully and effectively use the device. For maintenance and troubleshooting, basic technical knowledge for the device will help users.

For your maintenance and troubleshooting needs, follow the instructions specified in the manual.

If any unexpected errors or troubles occur, make sure to contact one of our service centers for help.

Prohibition and limitation

1. The details of the user manual can be changed without a prior notice.
Our company is not responsible for the direct and/or indirect loss or damages caused by results of handling or operating the product in any case and for the results occurring from user's negligence.
2. The act of duplicating or printing a bill, revenue stamp, bond, share certificate, bank draft, check, passport, and driver's license distributed at home and abroad is prohibited according to a law.
3. The copyrighted literary works such as books, cores, figures, maps, drawings, and photos can be duplicated and used for personal use or household use and within the same scope. In other cases, it is prohibited according to a law.
4. The above details present only a part of the applicable laws and regulations. The details of the law are not stated as they are. Our company is not responsible for correctness and completeness. Receive a legal consulting service to check if the duplication or printing of an object is legal.
5. The font used for device GUI and user manual is NANUM font, provided by NAVER.

Table of contents

Chapter 1. Safety Information

1.	Introduction	1-2
2.	Environmental information	1-3
	Environmental benefits of power management	1-3
	Recycled paper	1-3
	Duplex	1-3
3.	Safety information	1-4
	Warning and precaution symbols	1-4
	These are some of major exemplary graphical symbols	1-4
	<Power source connection>	1-5
	<Installation>	1-6
	<Using the product>	1-8
	<Consumables>	1-9
4.	Regulation notices	1-11
	For Brasilia users/ Para usuários de Brasília	1-12
	Laser safety	1-12
	Internal laser radiation	1-12
	CDRH regulations	1-13
	For European users	1-13
	Laser safety label	1-13
	Ozone release	1-14
	Acoustic noise (for German users only)	1-14
	Notification for California customers	1-14
	Recycling batteries (for Taiwan users only)	1-14
	For EU member states only	1-15
	Telephone cable (for users in countries subject to class B regulations)	1-15
	USB host	1-15
	Graphic symbols used on this machine	1-15
5.	Special notice to user	1-17
	For U.S.A.	1-17
	For Europe	1-18
	For New Zealand	1-18
6.	Space requirements	1-19

7.	Operation precautions	1-20
	Power source	1-20
	Operating environment	1-20
	Storage of copies	1-20
	Data stored in this machine	1-20
8.	Legal restrictions on reproduction	1-21
9.	Caution notations and labels	1-22

Chapter 2. Before Using This Machine

1.	Environmental initiatives	2-2
2.	Intended use of office MFP devices	2-3
	Intended use	2-3
	Impermissible operating conditions	2-3
	Exclusion of liability	2-3
3.	Target groups	2-4
4.	Introduction to user's guide	2-5
	Quick Guide	2-5
	HTML User's Guide	2-5
5.	Symbols and notations used in this manual	2-6
6.	Administrator password	2-7

Chapter 3. How to Use the HTML User's Guide About

	About the HTML User's Guide	3-2
	Operating environment	3-2

Chapter 4. About This Machine

1.	Optional components	4-2
	List of optional components	4-2
	List of other optional components	4-4

2.	Name of each component (main unit) -----	4-6
	Front -----	4-6
	Side/rear -----	4-7
3.	Power supply -----	4-8
	Turning the power on and off -----	4-8

Chapter 5. About Panels

1.	Control Panel -----	5-2
2.	Touch Panel -----	5-3
	Home screen -----	5-3
3.	Login methods -----	5-5
	When user authentication is enabled: -----	5-5

Chapter 6. Loading the Original and Paper

1.	Load the original -----	6-2
1.1	Loading the original into the ADF -----	6-2
1.2	Placing the original on the Original Glass -----	6-2
2.	Loading paper -----	6-3
2.1	Loading paper in Tray 1 to Tray 2 -----	6-3
	Applicable paper types -----	6-3
	How to load a paper -----	6-3
2.2	Loading paper into the Bypass Tray -----	6-4
	Applicable paper types -----	6-4
	How to load paper -----	6-4
2.3	Loading envelopes -----	6-5
2.4	Loading postcards -----	6-7
2.5	Loading label sheets -----	6-8
2.6	Loading index papers -----	6-9

Chapter 7. Available Operations in this Machine

1. How to copy	7-2
Basic copy operations	7-2
2. How to print	7-4
Basic print operations	7-4
3. How to print	7-5
Basic scan operations	7-5
4. How to fax	7-7
Basic fax operations	7-7

Chapter 8. Registering a Destination

1. How to register a destination	8-2
Registering a fax address	8-2
Registering E-mail address	8-3

Chapter 9. Read this if You Have a Problem

1. Main messages and remedies	9-2
1.1 Checking a notification message on the Touch Panel	9-2
1.2 Screen that appears when a paper/staple jam has occurred	9-3
1.3 When an error message appears	9-4
2. When the Touch Panel is not visible	9-5
3. When printing quality has deteriorated	9-6
Cleaning the Original Glass and roller	9-6
Cleaning the Slit Scan Glass	9-7
Cleaning the Print Head Glass	9-8
4. When a message appears to replace consumables or carry out cleaning	9-10
4.1 About Developing Unit	9-10
4.2 About Imaging Unit	9-10
4.3 About Drum Unit	9-10
Replacing a Drum Unit	9-11

4.4	About Toner Cartridge -----	9-12
	When toner is running out in the Toner Cartridge -----	9-12
	When it is time to replace a Toner Cartridge -----	9-12
	Replacing a Toner Cartridge -----	9-13
4.5	About Waste Toner Box -----	9-14
	Replacing a Waste Toner Box -----	9-14
4.6	About Staple Cartridge -----	9-16
	Replacing a Staple Cartridge (for Finisher FS-533) -----	9-18
	Replacing a Saddle Staple Cartridge (for Finisher FS-539 SD) -----	9-20
4.7	About hole-punch scraps -----	9-24
	Punch scrap processing (for Finisher FS-539 / Finisher FS-539 SD) -----	9-24
	Punch scrap processing (for Finisher FS-533) -----	9-25

D330E Series
Quick Start Guide

Safety information

1

1. Introduction

This **[Quick Guide]** uses illustrations to describe operating procedures for the most commonly used functions in an easy-to-understand way. Start by using this manual to become proficient with the useful functions that this machine offers. For details on the various functions, refer to the User's Guides on the User's Guide CD included with this machine.

In order to operate the machine safely and properly, be sure to read the safety information on page 1 of this manual before use. In addition, this manual contains the following information. Be sure to read the manual before using the machine.

- Items that must be observed to use the machine safely
- Information regarding product safety
- Precautions when using the machine

The illustrations and screens used in this manual may appear slightly different from views of the actual equipment and screens.

Tips

- Please keep this manual as well as the attached CD/DVD in a safe place where you can access them easily.

2. Environmental information

Environmental benefits of power management

Electricity consumption of a device depends on both its properties and the way of using the device. Suitable power management setting offers you resource saving usage way.

By setting the time to go into power saving modes (e.g. sleep mode) shorter (or optimal), electricity consumption can be reduced.

Recycled paper

This product can print on recycled paper and environmental stewardship initiatives certified paper which complies with European standard EN 12281 as well as virgin paper.

In addition it can print on lighter paper, 64g/m² for example. Using such light paper contributes to resources-saving.

Duplex

printing With a product which has a duplex unit, you can print on both sides of paper automatically. Using this function leads to reducing consumption of natural resources and your cost. Attached printer driver provides this duplex printing function as initial setting in your computer (The setting can be changed after installation manually).

3. Safety information

This section contains detailed instructions on the operation and maintenance of this machine. To achieve optimum utility of this device, all operators should carefully read and follow the instructions in this manual. Please read the following section before connecting the machine to the supply. It contains important information related to user safety and preventing equipment problems. Make sure that you observe all of the precautions that appear in different sections of this manual.

Reference

- Some parts of the contents of this section may not correspond with the purchased product.

Warning and precaution symbols

Be sure to observe the safety precautions. This manual contains the instructions that should be strictly observed at all times to prevent injury to yourself and other persons as well as damage to property. Injuries and damage that might be caused by using the product improperly are classified according to the following symbols.









Warning

- Improper handling can cause serious injury or death.







Caution







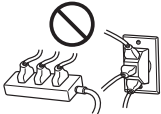

- Improper handling can cause minor injury or damage to houses and property.

These are some of major exemplary graphical symbols.



Symbols/Notations	Description	Symbols/Notations	Description	Symbols/Notations	Description
	General prohibition		Do not disassemble		Do not touch
	General instruction		Ground/Earth		Unplug from outlet
	General precaution		High temperature		Electrical shock hazard









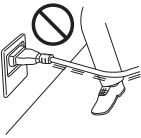

<Power source connection>

Graphic symbols	Descriptions	
 WARNING	<p>Do not use any power cord other than the one supplied in the package or attached on the products. If a power cord is not supplied, use only the power cord and plug that are specified in the user documentation. Failure to use this cord could result in a fire or electrical shock. If the power cord supplied in the package cannot be used in the country where this product was sold, use a power cord that meets the following conditions or contact your Technical Representative.</p> <ul style="list-style-type: none"> - The power cord has voltage and current rating appropriate for the rating plate on this machine. - The power cord meets regulatory requirements for the area. - The power cord is provided with grounding pin/ terminal. 	
	<p>Do not use the power cord to other products. Failure to do that could result in a fire or electrical shock.</p>	
	<p>Do not scratch, abrade, place a heavy object on, heat, twist, bend, step on, pull on, or damage the power cord. Use of a damaged power cord (exposed core wire, broken wire, etc.) could result in a fire or breakdown. Should any of these conditions be found, immediately turn OFF the power switch, unplug the power cord from the power outlet, and then call your authorized service representative.</p>	
	<p>Do not use the power source voltage other than being specified on the machine. Failure to do that could result in a fire or electrical shock.</p>	
	<p>Do not use a multiple outlet adapter to connect any other appliances or machines. Use of a power outlet for more than the marked current value could result in a fire or electrical shock.</p>	
	<p>Do not use an extension cord. Use of an extension cord could cause a fire or electric shock. If the power cord furnished with the product is not long enough to be plugged into a wall outlet, contact your Technical Representative.</p>	







Graphic symbols	Descriptions	
 WARNING	Do not unplug and plug in the power cord with a wet hand, as an electrical shock could result.	
	Plug the power cord all the way into the power outlet. Failure to do this could result in a fire or electrical shock.	
	Make sure to ground this product. (Connect the power cord to an electrical outlet that is equipped with a grounding terminal.) Failure to do so and an unlikely event of leakage could result in a fire or electrical shock.	
 CAUTION	The outlet must be near the equipment and easily accessible. Otherwise you can not pull out the power plug when an emergency occurs.	
	Do not place any objects around the power plug, as the power plug may be difficult to pull out when an emergency occurs.	
	Do not tug the power cord when unplugging. Pulling on the power cord could damage the cord, resulting in a fire or electrical shock.	
	Remove the power plug from the outlet more than one time a year and clean the area between the plug terminals. Dust that accumulates between the plug terminals may cause a fire.	









<Installation>

Graphic symbols	Descriptions	
 WARNING	Keep this bag away from babies and children. Do not use in cribs, beds, carriages, or playpens. The thin film may cling to nose and mouth and prevent breathing. This bag is not a toy.	 





Graphic symbols	Descriptions	
 WARNING	<p>Do not place a flower vase or other container that contains water, or metal clips or other small metallic objects on this product. Spilled water or metallic objects dropped inside the product could result in a fire, electrical shock, or breakdown.</p> <p>Should a piece of metal, water, or any other similar foreign matter get inside the product, immediately turn OFF the power switch, unplug the power cord from the power outlet, and then call your Technical Representative or your authorized service representative.</p>	
	<p>Make sure that the power cord is placed on a site in which no person would step on or trip over it. Stepping on or tripping over the power cord could heat the power cord, resulting in a fire or electric shock.</p>	
 CAUTION	<p><If instructed to use fixing legs>></p> <p>When the product has been installed, fix the product using the fixing legs. Not using the fixing legs could cause the product to move or topple over.</p>	
	<p>Do not place the product in a dusty place, or a site exposed to soot or steam, near a kitchen table, bath, or a humidifier. A fire, electrical shock, or breakdown could result.</p>	
	<p>Do not place this product on an unstable or tilted bench, or in a location subject to a lot of vibration and shock. It could drop or fall, causing personal injury or mechanical breakdown.</p>	
	<p>Do not let any object plug the ventilation holes of this product. Heat could accumulate inside the product, resulting in a fire or malfunction.</p>	
	<p>Whenever moving this product, be sure to disconnect the power cord and other cables. Failure to do this could damage the cord or cable, resulting in a fire, electrical shock, or breakdown.</p>	
	<p>When moving this product, always hold it at the locations specified in the User's Guide or other documents. If the unit is moved while held at locations other than those specified, it may fall, causing severe personal injury.</p>	











<Using the product>

Graphic symbols	Descriptions	
 WARNING	<p>Do not modify this product, as a fire, electrical shock, or breakdown could result. If the product employs a laser, the laser beam source could cause blindness.</p>	
	<p>Do not attempt to remove the covers and panels which have been fixed to the product. Some products have a high-voltage part or a laser beam source inside that could cause an electrical shock or blindness.</p>	
	<p>Do not keep using this product, if this product becomes inordinately hot or emits smoke, or unusual odor or noise. Immediately turn OFF the power switch, unplug the power cord from the power outlet, and then call your Technical Representative or your authorized service representative. If you keep on using it as is, a fire or electrical shock could result.</p>	
	<p>Do not keep using this product, if this product has been dropped or its cover damaged. Immediately turn OFF the power switch, unplug the power cord from the power outlet, and then call your Technical Representative or your authorized service representative. If you keep on using it as is, a fire or electrical shock could result.</p>	
	<p>Do not use flammable sprays, liquids, or gases inside or near this machine. Do not clean the inside of this machine using a flammable gas duster. A fire or explosion could result.</p>	
	<p><If an RFID module (limited only to 13.56 MHz) for use in inside-the-machine proximity communication or electromagnetic induction heating (IH) technology (limited only to 20.05 kHz to 100 kHz) is being used> This machine generates a weak magnetic field. If you experience any unusual symptoms with your implantable medical equipment (cardiac pacemaker, etc.) while near the machine, move away from the machine and see a doctor immediately. Please call your Technical Representative or your authorized service representative if you do not understand the purchased product corresponds or not.</p>	

Graphic symbols	Descriptions	
 WARNING	<p><If a non-contact IC card reader is being used> If you use an implantable medical equipment (cardiac pacemaker, etc.), do not bring the IC card reader close from the implant within 12 cm at all times. The radio waves may affect implantable medical equipment (cardiac pacemaker, etc.) operations.</p>	
 CAUTION	<p>Using this product in a poorly ventilated room for a long time or producing a large volume of copies or prints may cause the odor of exhaust air from the machine. Ventilate the room well.</p>	
	<p>The inside of this product has areas subject to high temperature, which may cause burns. When checking the inside of the unit for malfunctions such as a paper misfeed, do not touch the locations (around the fusing unit, etc.) which are indicated by a “Caution HOT” caution label. A burn could result.</p>	 
	<p>Unplug the product when you will not use the product for long periods of time.</p>	
	<p>When using the machine, do not look at the light of the lamp for a prolonged time. Eyestrain could result.</p>	
	<p>Do not use stapled paper, conductive paper (such as silver paper or carbon paper) or treated heat-sensitive/inkjet paper, otherwise a fire may result.</p>	

<Consumables>

Graphic symbols	Descriptions	
 WARNING	<p>Do not throw toner or a container that contains toner (e.g., toner cartridge and developing unit) into an open flame. The hot toner may scatter and cause burns or other damage.</p>	
 CAUTION	<p>Do not leave toner-related parts (e.g., toner cartridge and developing unit) within easy reach of children. Licking any of these parts or ingesting toner could damage your health.</p>	

Graphic symbols	Descriptions	
 CAUTION	<p>Do not store toner-related parts (e.g., toner cartridge and developing unit) near devices susceptible to magnetism, such as precision equipment and data storage devices, otherwise they may malfunction. They could cause these products to malfunction.</p>	
	<p>Do not force open the toner-related parts (e.g., toner cartridge and developing unit). If toner tumbles from the toner bottle, take utmost care to avoid inhaling it or even getting skin contact.</p>	
	<p>If toner lands on your skin or clothing, wash thoroughly with soap and water.</p>	
	<p>If you inhale toner, move to a place with fresh air and gargle with a lot of water repeatedly. Should you get symptoms such as coughing, seek medical advice.</p>	
	<p>If you get toner into your eyes, immediately rinse them with running water for over 15 minutes. Seek medical advice if irritation persists.</p>	
	<p>If you swallow toner, rinse out your mouth and drink a few glasses of water. Seek medical advice if necessary.</p>	
	<p>Never touch the electrical contacts of the units (e.g., toner cartridge and developing unit), as an electrostatic discharge may damage the product.</p>	
	<p>Before handling, see the user documentation for the safety information.</p>	
	<p><If instructed to replace the fusing unit> The fusing section is extremely hot. Before replacing the fusing unit, be sure to open doors and covers of the machine. Then, leave the machine to stand idle for a specified period of time and make sure that the fusing section has cooled down to room temperature. Failure to follow these instructions could result in a burn.</p>	

4. Regulation notices

Maximum radio-frequency power transmitted in the frequency band (EIRP):

MModule Name, Option	Frequency Band	Radiation. Power
UK-221 includes approved Wireless module, MODEL WN4521L:	2.4 GHz	Max. 20 dBm
	5 GHz	Max. 23 dBm
EK-609 includes approved Wireless module, MODEL MBH7BLZ02:	2.4 GHz	Max. 3 dBm

Note: 5 GHz may not be available

This radio equipment is restricted to indoor use only. Outdoor use is prohibited.

This restriction applies to all the countries listed in the table below.



AT	BE	BG	CH	CY	CZ	DE	DK	EE
EL	ES	FI	FR	HR	HU	IE	IS	IT
LI	LT	LU	LV	MT	NL	NO	PL	PT
RO	SE	SI	SK	TK	UK			

For Brasilia users/ Para usuários de Brasília

The UK-221 (includes wireless module, model WN4521L) are not provide for the Brazilian market./ O UK-221 (inclui módulo sem fio, model WN4521L) não é fornecido para o mercado brasileiro.

Laser safety

This is a digital machine which operates using a laser. There is no possibility of danger from the laser provided the machine is operated according to the instructions in the manuals. Since radiation emitted by the laser is completely confined within protective housing, the laser beam cannot escape from the machine during any phase of user operation. This machine is certified as a Class 1 laser product per IEC 60825-1: 2014: This means the machine does not produce hazardous laser radiation.

Internal laser radiation

Maximum Average Radiation Power: 5.7 μ W at the laser aperture of the print head unit.

Wavelength: 770-800 nm This product employs a Class 3B laser diode that emits an invisible laser beam. The laser diode and the scanning polygon mirror are incorporated in the print head unit.

The print head unit is NOT A FIELD SERVICE ITEM: Therefore, the print head unit should not be opened under any circumstances.



CDRH regulations

This machine is certified as a Class 1 Laser product under Radiation Performance Standard according to the Food, Drug and Cosmetic Act of 1990. Compliance is mandatory for Laser products marketed in the United States and is reported to the Center for Devices and Radiological Health (CDRH) of the U.S. Food and Drug Administration of the U.S. Department of Health and Human Services (DHHS). This means that the device does not produce hazardous laser radiation. The label shown on page 5 indicates compliance with the CDRH regulations and must be attached to laser products marketed in the United States.

Warning

Use of controls, adjustments or performance of procedures other than those specified in this manual may result in hazardous radiation exposure.

- **This is a semiconductor laser. The maximum power of the laser diode is 20 mW and the wavelength is 770-800 nm.**

For European users

Warning

Use of controls, adjustments or performance of procedures other than those specified in this manual may result in hazardous radiation exposure.

- **This is a semiconductor laser. The maximum power of the laser diode is 20 mW and the wavelength is 770-800 nm.**

Laser safety label

A laser safety label is attached to the outside of the machine, as shown below.

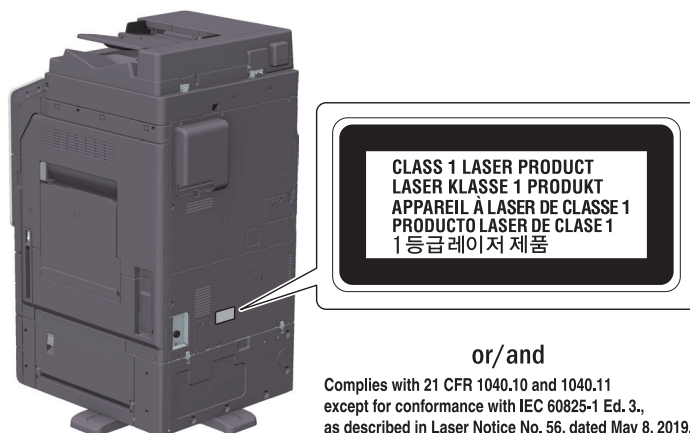

Ozone release

Locate the Machine in a Well-Ventilated Room A negligible amount of ozone is generated during normal operation of this machine. An unpleasant odor may, however, be created in poorly ventilated rooms during extensive machine operations. For a comfortable, healthy and safe operating environment, it is recommended that the room be well ventilated. Placer l'appareil dans une pièce largement ventilée Une quantité d'ozone négligable est dégagée pendant le fonctionnement de l'appareil quand celui-ci est utilisé normalement. Cependant, une odeur désagréable peut être ressentie dans les pièces dont l'aération est insuffisante et lorsque une utilisation prolongée de l'appareil est effectuée. Pour avoir la certitude de travailler dans un environnement réunissant des conditions de confort, santé et de sécurité, il est préférable de bien aérer la pièce où se trouve l'appareil.

Acoustic noise (for German users only)

Der höchste Schalldruckpegel beträgt 70 dB(A) oder weniger gemäß EN ISO 7779.

Notification for California customers

This product uses a CR Lithium Battery which contains perchlorate material. This perchlorate warning applies to perchlorate-containing lithium batteries sold or distributed in California, USA. "Perchlorate Material - Special handling may apply."

Recycling batteries (for Taiwan users only)

根據地方規定處理使用的電池。



This symbol means: Do not dispose of this product together with your household waste!

Please refer to the information of your local community or contact our dealers regarding the proper handling of end-of-life electric and electronic equipments. Recycling of this product will help to conserve natural resources and prevent potential negative consequences for the environment and human health caused by inappropriate waste handling.

For EU member states only

This product complies with RoHS (2011/65/EU) Directive.

Telephone cable (for users in countries subject to class B regulations)

Connect a telephone cable with a ferrite core to the telecommunication port of this machine. (Connect the modular jack on the ferrite-core-equipped end of the telephone cable to the telecommunication port.)

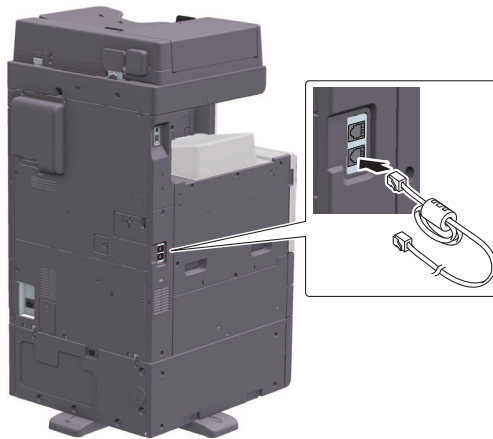















USB host

Connect USB devices (Memory, Authentication, Hub etc.) devices directly to the USB host. If an extension cable is used, electromagnetic interference could occur.

Graphic symbols used on this machine

These are some of major exemplary graphical symbols.

Graphic symbols	Descriptions	Graphic symbols	Descriptions
	“ON” position		“OFF” position
	STAND-BY		push-push type switches
	Ground/Earth (Protective bonding terminal)		Ground/Earth (Protective earthing)
	CLASS II EQUIPMENT		Class II equipment with functional earthing

Graphic symbols	Descriptions	Graphic symbols	Descriptions
	Functional earthing		General precaution
	High temperature		Electrical shock hazard
	CAUTION moving fan blade		CAUTION DOUBLE POLE / NEUTRAL FUSING

5. Special notice to user

For U.S.A.

FCC PART 68 REQUIREMENTS: This equipment complies with Part 68 of the FCC rules and the requirements adopted by the ACTA. On the cover of this equipment is a label that contains, among other information, a product identifier in the format US:AAAEQ##TXXXX. If required, this information must be provided to the telephone company.

This equipment uses certification jack USOC RJ11C.

A plug and jack used to connect this equipment to the premises wiring and telephone network must comply with the applicable FCC Part 68 rules and requirements adopted by the ACTA.

A compliant telephone cord and modular plug is provided with this product. It is designed to be connected to a compatible modular jack that is also compliant. See installation instructions for details.

The REN is used to determine the number of devices that may be connected to a telephone line. Excessive RENs on a telephone line may result in the devices not ringing in response to an incoming call. In most but not all areas, the sum of RENs should not exceed five (5.0).

To be certain of the number of devices that may be connected to a line, as determined by the total RENs, contact the local telephone company. For products approved after July 23, 2001, the REN for this product is part of the product identifier that has the format US: AAAEQ##TXXXX. The digits represented by ## are the REN without a decimal point (e.g., 03 is a REN of 0.3). For earlier products, the REN is separately shown on the label.

The telephone company may make changes in its facilities, equipment, operations or procedures that could affect the operation of the equipment. If this happens the telephone company will provide advance notice in order for you to make necessary modifications to maintain uninterrupted service.

If trouble is experienced with this equipment FK-513, for repair or warranty information, please contact the dealer location where you purchased this equipment. If the equipment is causing harm to the telephone network, the telephone company may request that you disconnect the equipment until the problem is resolved.

Connection to party line service is subject to state tariffs. Contact the state public utility commission, public service commission or corporation commission for information. If your home has specially wired alarm equipment connected to the telephone line, ensure the installation of FK-513 does not disable your alarm equipment. If you have questions about what will disable alarm equipment, consult your telephone company or a qualified installer.

The Telephone Consumer Protection Act of 1991 makes it unlawful for any person to use a computer or other electronic device, including FAX machines, to send any message unless such message clearly contains in a margin at the top or bottom of each transmitted page or on the first page of the transmission, the date and time it is sent and an identification of the business or other entity, or other individual sending the message and the telephone number of the sending machine or such business, other entity, or individual. (The telephone number provided may not be a 900 number or any other number for which charges exceed local or long-distance transmission charges.)

In order to program this information into your FAX machine, you should complete the following steps: See Sending after Renaming the Sender (**[Sender Settings]**), of the User's Guide **[Fax]**.

WARNING/CAUTION Explained

Warning

- **The exclamation point within an equilateral triangle followed by the word “Warning” is intended to alert the user to the possibility that a disregard for the warning may result in fatal hazards or critical injuries. Be sure to focus your attention on the Warning headings when reading this Quick Guide.**

Caution

- **The exclamation point within an equilateral triangle followed by the word “Caution” is intended to alert the user to the possibility that a disregard for the caution may result in minor injuries or in physical damage. Be sure to focus your attention on the Caution headings when reading this Quick Guide.**

For Europe

The Facsimile has been confirmed to meet the standards (or requirements) ETSI for pan-European single terminal connection to the public switched telephone network (PSTN).

For New Zealand

This device is equipped with pulse dialing while the Telecom standard is DTMF tone dialing. There is no guarantee that Telecom lines will always continue to support pulse dialing.

Use of pulse dialing, when this equipment is connected to the same line as other equipment, may give rise to bell tinkle or noise and may also cause a false answer condition. Should such problems occur, the user should not contact the Telecom Fault Service.

This equipment may not provide for the effective hand-over of a call to another device connected to the same line.

The grant of a Telepermit for any item of terminal equipment indicates only that Telecom has accepted that the item complies with minimum conditions for connection to its network. It indicates no endorsement of the product by Telecom, nor does it provide any sort of warranty.

Above all, it provides no assurance that any item will work correctly in all respects with another item of Telepermitted equipment of a different make or model, nor does it imply that any product is compatible with all of Telecom's network services.

The automatic calling functions of this equipment must not be used to cause a nuisance to other customers.

Telepermitted equipment only may be connected to the auxiliary telephone port. The auxiliary port is not specifically designed for 3-wire connected equipment. 3-wire might not respond to incoming ringing when connected to this port.

6. Space requirements

To ensure that machine operation, consumables replenishing, part replacement, and regular maintenance can easily be performed, adhere to the recommended space requirements detailed below.

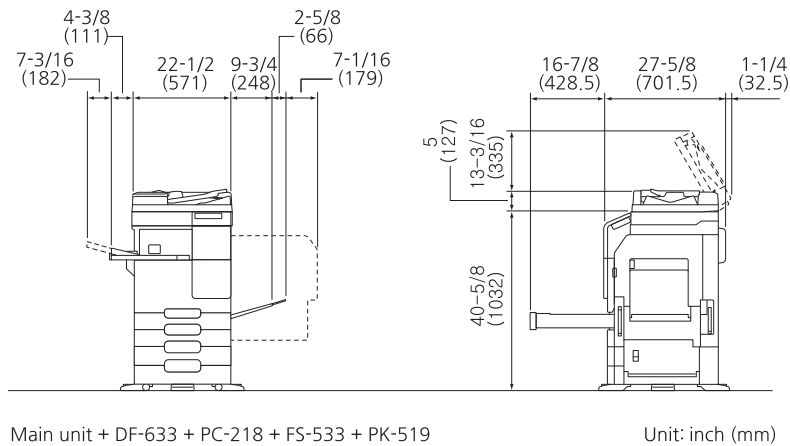
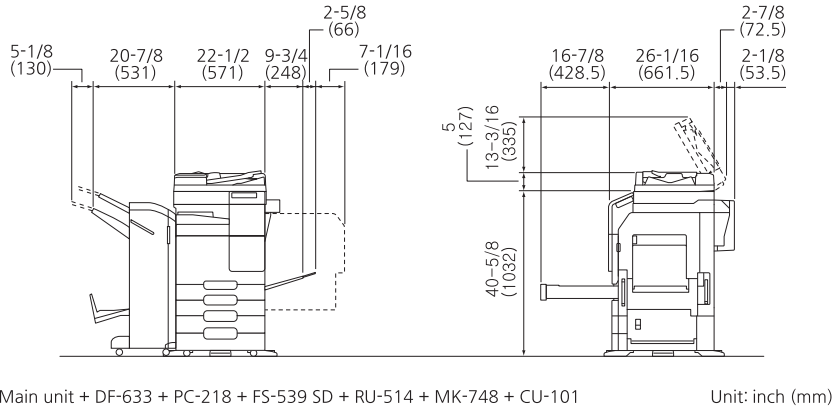

Notice

Be sure to allow a clearance of 8 inches (200 mm) or more at the back of this machine for the ventilation duct.

7. Operation precautions

To ensure the optimum performance of this machine, observe the precautions described below.

Power source

The power source requirements are as follows.

- Voltage fluctuation: Maximum $\pm 10\%$ (at 110 V/120 V/220 to 240V AC)
- Frequency fluctuation: Maximum ± 3 Hz (at 50 Hz/60 Hz)
- Use a power source with as little voltage or frequency fluctuations as possible.

Operating environment

The environmental requirements for correct operation of the machine are as follows.

- Temperature: 50°F (10°C) to 86°F (30°C) with fluctuations of no more than 18°F (10°C) within an hour
- Humidity: 15% to 85% with fluctuations of no more than 10% within an hour

Storage of copies

To store copies, follow the recommendation listed below.

- Copies that are to be kept for a long time should be kept where they are not exposed to light in order to prevent them from fading.
- Adhesive that contains solvent (e.g., spray glue) may dissolve the toner on copies.
- Color copies have a thicker layer of toner than normal black-and-white copies. Therefore, when a color copy is folded, the toner at the fold may peel off.

Data stored in this machine

It is suggested to delete all data stored in all storage areas using the overwrite all data function to prevent leakage of data prior to transfer or disposal of the machine, or returning of the leased machine. For details of the overwrite all data function, refer to the User's Guide.

Contact your service representative before deleting data. It is recommended to backup storage periodically as the measures for storage defect. For the detail information of storage backup, contact your service representative.

8. Legal restrictions on reproduction

Certain types of originals must never be reproduced with the purpose or intent to pass reproductions of such originals off as the originals.

The following is not a complete list, but is meant to be used as a guide to responsible reproduction.

<Financial Instruments>

- Personal checks
- Traveler's checks
- Money orders
- Certificates of deposit
- Bonds or other certificates of indebtedness
- Stock certificates

<Legal Originals>

- Food stamps
- Postage stamps (canceled or uncanceled)
- Checks or drafts drawn by government agencies
- Internal revenue stamps (canceled or uncanceled)
- Passports
- Immigration papers
- Motor vehicle licenses and titles
- House and property titles and deeds

<General>

- Identification cards, badges, or insignias
- Copyrighted works without permission of the copyright owner

In addition, it is prohibited under any circumstances to reproduce domestic or foreign currencies, or works of art without permission of the copyright owner.

When in doubt about the nature of an original, consult with legal counsel.

Notice

- This machine provides the forgery prevention function in order to prevent financial instruments from being reproduced illegally.
- We appreciate your understanding that printed images may infrequently have some noise or image data may not be stored under certain circumstances due to this forgery prevention function.

9. Caution notations and labels

Safety precaution notations and labels appear on this machine at the following positions. Be very careful that an accident does not occur when operations such as removing paper jams and staple jams are performed.

CAUTION
It is illegal to reproduce certain types of documents. Do not reproduce such documents.

WARNING
Do not alter or remove any covers or panels attached to this machine. Some products have a high-voltage part or a laser beam source inside that could cause an electrical shock or blindness.

WARNING
Do not throw a container that contains toner into an open flame. The hot toner may scatter and cause burns or other damage.

CAUTION
When the Mount Kit MK-603 is installed, the area around the indicated part is extremely hot. Touching the area around the indicated part may result in burns.

WARNING
Do not throw a container that contains toner into an open flame. The hot toner may scatter and cause burns or other damage.

CAUTION
Do not position the used waste-toner box so that it is standing on end or tilted, otherwise toner may spill.

CAUTION
When the Heater HT-509 is installed, the area around the indicated part is extremely hot. Touching the area around the indicated part may result in burns.

CAUTION
The inside of this product has areas subject to high temperature, which may cause burns. When checking the inside of the unit for malfunctions such as a paper misfeed, do not touch the locations (around the fusing unit, etc.) which are indicated by a "Caution HOT" caution label. A burn could result.

CAUTION
Do not put your finger into the gap. Otherwise, your finger may touch the moving part, causing an injury.

<FS-539/FS-539 SD >



CAUTION
Do not put your finger into the gap. Otherwise, your finger may touch the moving part, causing an injury.

 **Notice**

- Do not remove caution labels or notations. If any caution label or caution notation is soiled, please clean to make legible. If you cannot make them legible, or if the caution label or notation is damaged, please contact your service representative.

D330E Series
Quick Start Guide

**Before Using This
Machine**

2

1. Environmental initiatives

The company continuously strives to reduce the negative environmental impacts of all stages of its business operations.

As part of such activities, the company is implementing resource-saving steps by reducing the number of pages in the User's Guide.

For the information necessary to operate the machine, please refer to the bundled User's Guide CD (HTML format). This guide has an excellent search function.

Functions such as keyword search and filtering by purpose are very useful to help users find what they need to know.

2. Intended use of office MFP devices

Intended use

This Multi Function Product incorporates the functionality of multiple office devices in one. It is designed to be used as an office system for the following purposes:

- Print, copy, scan and fax documents.
- Use available finishing functions such as duplexing, stapling, hole-punching and booklet creation if appropriate options are installed.
- Store scanned documents on external USB memory devices; send scanned documents to network scan destinations such as FTP, WebDAV and Email.

The intended use also requires that:

- The system is used within the limits of device specifications and specifications of optional components,
- All safety instructions in the related user's guides are observed,
- Legal restrictions on reproduction (page 7) are observed,
- Inspection and maintenance instructions are adhered to,
- General, national and company safety provisions are observed.

Impermissible operating conditions

The system may not be operated if:

- Errors or damage have been discovered,
- Maintenance intervals have been exceeded,
- Mechanical or electrical functions do not work as they should.

Exclusion of liability

The manufacturer of the system assumes no liability for damages if the system was operated under impermissible conditions.

3. Target groups

The user's guides are intended for the following users of the system:

Target group	Descriptions
User	Persons using the system for objectives described in “ Intended use of office MFP devices ” as well as managing system functions and consumables according to the assigned user rights.
Administrator	Persons managing consumables, system functions, users and access rights; adjusting system settings, and establishing network connections.

Everyone who uses this system must have read and understood the related user's guides.

4. Introduction to user's guide

The user's guide of this product consists of this manual and the HTML User's Guide.

This manual describes notes and precautions that should be followed in order to use this machine safely, and also provides information about basic functions and operation methods.

If you want to learn about more detailed functions or operation methods, refer to the HTML User's Guide included in the User's Guide CD.

Quick Guide





This document describes notes and precautions that should be followed in order to use this machine safely, and also provides information about basic functions and operation methods.

Be sure to read this guide before use.

HTML User's Guide

This User's Guide is included in the User's Guide CD. The User's Guide provides basic and detailed information on the functions of this product and also explanations of other various setting functions.

5. Symbols and notations used in this manual

Symbol/notation	Descriptions
 Warning	Improper handling can cause serious injury or death.
 Caution	Improper handling can cause minor injury or damage to houses and property.
 Notice	This symbol indicates a risk that may result in damage to this machine or documents. Follow the instructions to avoid property damage.
✓	This check mark symbol shows a precondition of a procedure.
→	This symbol indicates a supplementary explanation of a procedural instruction.
 Tips	This symbol indicates supplemental information of a topic as well as options required to use a function.
 Reference	This symbol indicates reference functions related to a topic.
❖ Related setting	This shows the settings related to a particular topic for any user.
❖ Related setting (for the administrator)	This shows the settings related to a topic only for administrators.
[]	An item enclosed by brackets [] indicates a key name on the Touch Panel or computer screen, or the name of a user's guide.

6. Administrator password

The administrator password is set to **[1234567812345678]** by factory default. Try this password if the administrator password has not been changed. Change the administrator password periodically.

D330E Series
Quick Start Guide

**How to Use the HTML
User's Guide About**

3

About the HTML User's Guide

The HTML User's Guide included in the User's Guide CD can also be obtained from the following URL. To obtain the HTML User's Guide, send the URL read from the QR code to your computer. Select a desired function on the top page (Home), and check the details of the function.

Selecting **[Introduction]** on the top page (Home) allows you to view detailed methods for using the HTML User's Guide.

Operating environment

Supported operating systems

- Microsoft Windows 7 (SP1)/Windows 8.1/Windows 10
Apple Mac OS 10.11/10.12/10.13/10.14/10.15

Supported Web browsers

- **Windows:**
Microsoft Internet Explorer 10/11 (Desktop version), Microsoft Edge, Firefox latest version, Google Chrome latest version
- **Mac OS:**
Safari latest version

Display resolution

- 1024 x 768 pixels or more

Tips

- We recommend that you use the latest Web browser that is compatible with your operating system to help you use this machine more conveniently and comfortably.
- Check that JavaScript in your Web browser is enabled. The HTML User's Guide uses JavaScript for the page display and search functions.

D330E Series
Quick Start Guide

About This Machine

4

1. Optional components

List of optional components

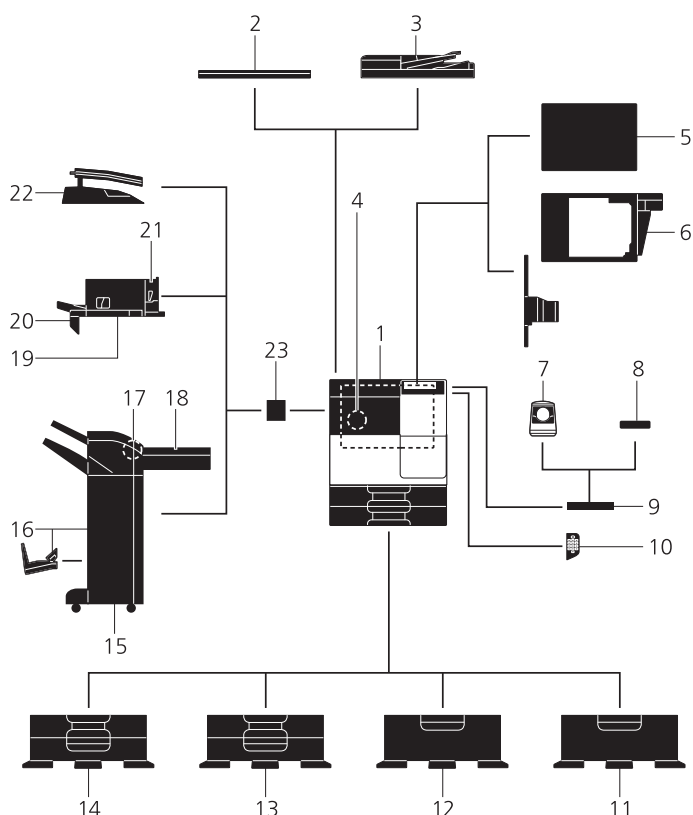

No.	Name	Descriptions
1	Main unit	Scans the original in the scanner section, and prints a scanned image in the printer section. This unit is referred to as “this machine” or “the main unit” in the manual.
2	Original Cover OC-513	Used to fix the loaded originals.
3	Reverse Automatic Document Feeder DF-633	Automatically feeds and scans originals by page. This unit also reverses and automatically scans 2-sided originals. This unit is referred to as ADF in the manual.
4	Fax Kit FK-513	Used to operate this machine as a fax machine. When you use this machine as a fax machine, the optional Expanded Memory Unit must also be installed in this machine.
5	Clean Unit CU-101	Collects small particles (UFP) generated in this machine to prevent them from escaping this machine. The Mount Kit MK-748 is required to install the Clean Unit CU-101 .
6	Mount Kit MK-748	This unit is required to install the Clean Unit CU-101 .

No.	Name	Descriptions
7	Authentication Unit AU-102	Performs user authentication by scanning vein patterns in the finger. The Working Table WT-515 is required to install the Authentication Unit AU-102 . To install, the Local Interface Kit EK-608 or Local Interface Kit EK-609 is required.
8	Authentication Unit AU-201S	Performs user authentication by scanning information recorded on the IC card or NFC-compatible Android terminal. The Mount Kit MK-735 is required to install the Authentication Unit AU-201S . This unit can also be installed on the Working Table WT-515 . To install, the Local Interface Kit EK-608 or Local Interface Kit EK-609 is required.
9	Working Table WT-515	This is used when the Authentication Unit AU-102 or Authentication Unit AU-201S is installed.
10	Keypad KP-101	It is equipped on the side of the Control Panel . Allows you to operate this machine or enter a number by using hardware keys.
11	Desk DK-518	Used to install this machine on the floor.
12	Paper Feed Cabinet PC-418	Allows you to load up to 2500 sheets of 8-1/2 e 11 (A4) size.
13	Paper Feed Cabinet PC-218	Allows you to load up to 500 sheets respectively in the top and bottom trays.
14	Paper Feed Cabinet PC-118	Allows you to load up to 500 sheets in the top tray and use the bottom tray as a storage box.
15	Finisher FS-539	Sorts, groups and staples printed paper before outputting it. To install the Finisher FS-539 , the Relay Unit RU-514 and Mount Kit MK-603 are required. In addition, the Paper Feed Cabinet PC-118 , PC-218 , or PC-418 or Desk DK-518 must be installed on this machine.
16	Finisher FS-539 SD	Sorts, groups, staples, folds, and binds printed paper before outputting it. To install the Finisher FS-539 SD , the Relay Unit RU-514 and Mount Kit MK-603 are required. In addition, the Paper Feed Cabinet PC-118 , PC-218 , or PC-418 or Desk DK-518 must be installed on this machine.
17	Punch Kit PK-524	Install this unit onto the Finisher FS-539/FS-539 SD . This unit supports the punching function.
18	Relay Unit RU-514	This unit is required to install the Finisher FS-539/FS-539 SD on this machine.
19	Finisher FS-533	Install this unit onto the output tray of this machine. Sorts, groups and staples printed paper before outputting it. The Mount Kit MK-602 and Mount Kit MK-603 are required to install the Finisher FS-533 .
20	Mount Kit MK-602	This unit is required to install the Finisher FS-533 .

No.	Name	Descriptions
21	Punch Kit PK-519	Install this unit onto the Finisher FS-533 . This unit supports the punching function.
22	Job Separator JS-506	Install this unit onto the output tray of this machine. This unit sorts printed sheets. The Mount Kit MK-603 is required to install the Job Separator JS-506 .
23	Mount Kit MK-603	This unit is required to install the Finisher FS-539/FS-539 SD/FS-533 or Job Separator JS-506 on this machine.

List of other optional components

The following options are built into this machine and are not shown in the figure.

No.	Name	Descriptions
1	Local Interface Kit EK-608	Install this unit when using the voice guidance function. The speaker and USB port are added.
2	Local Interface Kit EK-609	Install this unit when using the voice guidance function or the connection function with a Bluetooth LE-compatible iOS terminal. The speaker, USB port, and receiving device for Bluetooth LE communication are added.
3	i-Option LK-102	Allows you to add the PDF processing function.
4	i-Option LK-104	Allows you to add the voice guidance function.
5	i-Option LK-105	Allows you to add the searchable PDF function.
6	i-Option LK-106	Used to add a bar code font that is one of special fonts.
7	i-Option LK-107	Used to add a unicode font that is one of special fonts.
8	i-Option LK-108	Used to add an OCR font that is one of special fonts. In the standard, the OCR-B font (PostScript) is available. Installing this option allows use of the OCR-A font (PCL).
9	i-Option LK-110	Allows you to convert a file into the DOCX or XLSX type or generate a high functionality and the high-quality data generation function. This option includes the function licenses for i-Option LK-102 and i-Option LK-105 . To purchase this option, you do not need to purchase i-Option LK-102 and i-Option LK-105 . For details on the addable functions, refer to the HTML User's Guide.
10	i-Option LK-111	Allows you to add the ThinPrint function.
11	i-Option LK-114	Allows you to add the serverless pull printing function.
12	i-Option LK-115	Allows you to add TPM (Trusted Platform Module). Security enhancement is realized by encrypting confidential information such as certificates and passwords of this machine.
13	i-Option LK-116	Allows you to add the virus scan function.

No.	Name	Descriptions
14	i-Option LK-117	Allows you to add the IP fax (SIP) function.
15	Upgrade Kit UK-221	Allows you to use this machine in a wireless network environment.
16	Heater HT-509	Prevents paper in a paper tray from being affected by humidity. The Heater HT-509 can be mounted when you purchase the Paper Feed Cabinet PC-118, PC-218, or PC-418.
17	Power Supply BOX MK-734	Used to turn on or off the operation of Heater HT-509 for paper feed cabinet. The Power Supply BOX MK-734 can be mounted when you purchase the Paper Feed Cabinet PC-118, PC-218 or PC-418 or Desk DK-518 .
18	Mount Kit MK-735	Required to have Authentication Unit AU-201S built in to the main unit.
19	Expanded Memory Unit EM-907	Used to increase the storage capacity to add functions.

2. Name of each component (main unit)

Front

This figure shows the main unit equipped with Reverse Automatic Document Feeder DF-633.

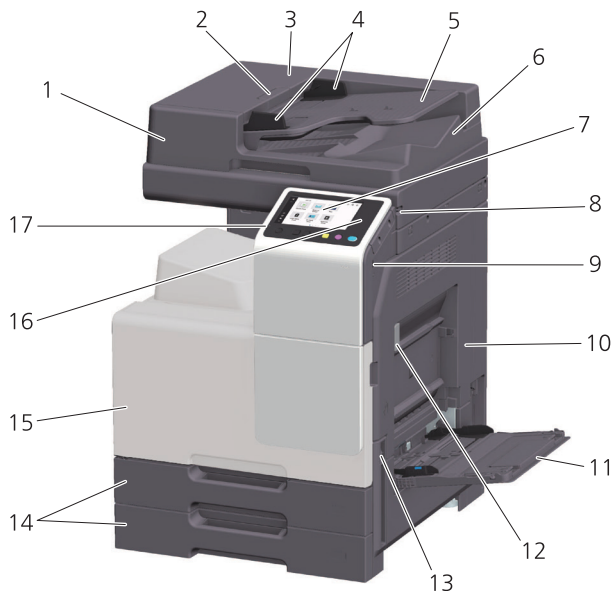

No.	Name	Descriptions
1	Reverse Automatic Document Feeder	Automatically feeds and scans originals by page. This unit also reverses and automatically scans 2-sided originals. This unit is referred to as ADF in the manual.
2	Left Cover Release Lever	Used to open the Left Cover.
3	Left Cover	Open the Left Cover when clearing a paper jam.
4	Lateral Guide	Adjust this guide along the width of the original.
5	Original Tray	Load the original face up in this tray.
6	Original Output Tray	The scanned original is fed out onto this tray.
7	Control Panel	Used to configure various settings in this machine.
8	Stylus Pen	Used to select a menu on the Touch Panel, or enter characters.
9	USB Port (Type A) USB2.0/1.1	Used to connect a USB flash drive to this machine.
10	Right Door	Open this door to clear a paper jam.
11	Bypass Tray	Used to print data on irregularly size paper, thick paper, transparencies, postcards (4 e 6 (A6 Card)), envelopes, or label sheets.
12	Right Door Release Lever	Used to lock the Right Door.

13	Main Power Switch	Press this switch to turn the machine on or off.
14	Tray 1, Tray 2	Allows you to load up to 500 sheets of plain paper.
15	Front Door	Open this door to replace the Toner Cartridge , Waste Toner Box, or Drum Unit, and to clean the Print Head Glass.
16	Mobile Touch Area	This area is used to associate this machine with an NFC-compatible Android terminal or an iOS terminal compatible with Bluetooth LE.
17	Power key	Switches this machine to the Power Save mode.

Side/rear

The illustration shows the main unit with **Reverse Automatic Document Feeder DF-633**, and **Fax Kit FK- 513**.

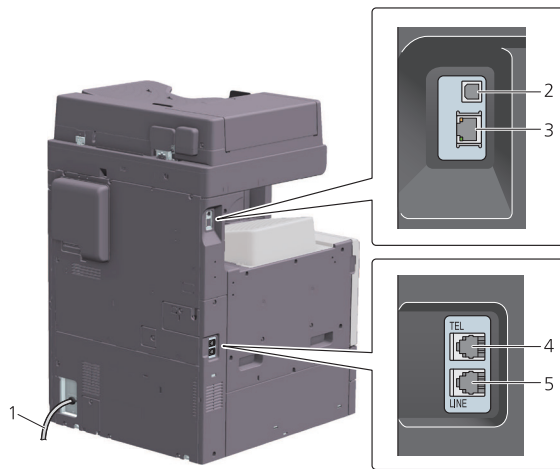

No.	Name	Descriptions
1	Power Cord	Used to supply power to this machine.
2	USB Port (Type B) USB2.0/1.1	Connect to this port when using this machine as a USB-connected printer.
3	Network Connector (10Base-T/100Base-TX/1000Base-T)	Connect to this port when using this machine as a network printer or network scanner.
4	Jack for connecting a telephone (TELPORT1)	Used to connect a telephone cord.
5	Telephone Jack 1 (LINE PORT1)	Used to connect a general telephone subscriber line.

Tips

- The network port of this product is following No.2 and No.3. A port is activated when a network port inserts a cable.

3. Power supply

This machine provides the Main Power Switch and Power key.



No.	Name	Descriptions
1	Main Power Switch	Turns the main power of this machine on or off. For details on how to turn the main power on or off, refer to page 17.
2	Power key	Switches this machine to the Power Save mode. This function reduces power consumption and has a greater power saving effect. For details on how to use the Power key, refer to HTML User's Guide.

 **Notice**

- While printing, do not turn the Main Power Switch off or press the Power key. Otherwise, it may lead to a paper jam.
- If the Main Power Switch is turned off or the Power key is pressed while this machine is running, the system deletes the currently loaded data or communicating data as well as queued jobs.

Turning the power on and off

- 1** When turning the main power on, press | of the Main Power Switch.

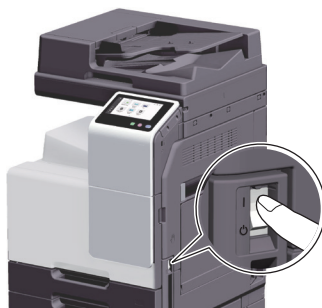

The Start key lights up orange, and the start screen is displayed on the Touch Panel.

- 2** When turning the main power off, press  of the **Main Power Switch**.

 **Notice**

- When restarting this machine, turn the Main Power Switch off and on again after 10 or more seconds have passed. Not doing so may result in an operation failure.

D330E Series
Quick Start Guide

About Panels

5

1. Control Panel

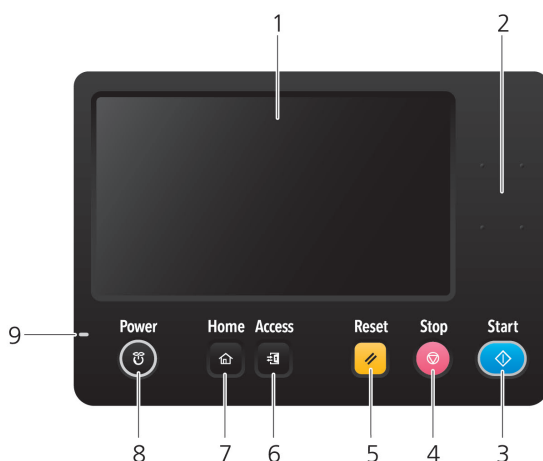



No.	Name	Descriptions
1	Touch Panel	Displays setting screens and messages. Directly press this panel to carry out operations.
2	Mobile Touch Area	This area is used to associate this machine with an NFC-compatible Android terminal or an iOS terminal compatible with Bluetooth LE.
3	Start	Press this key to start an operation such as printing.
4	Stop	Press this key to temporarily stop an active print job. <ul style="list-style-type: none"> To restart, press the Start key. To delete, select a target job in the currently stopped screen, and also tap [Delete].
5	Reset	Returns the setting you entered or changed to the default.
6	Access	Use this key to perform authentication in the Login screen if user authentication or account track is installed on this machine. Pressing the Access key while logged in will log you out of this machine.
7	Home	Displays the home screen.
8	Power key	Switches this machine to the Power Save mode. For details on how to use the Power key, refer to HTML User's Guide.
9	Warning Indicator	Indicates the status of this machine by the lamp color, flashing, or a lamp lighting up. <ul style="list-style-type: none"> Flash (orange): Warning Light-up (orange): The machine is stopped.

2. Touch Panel

Home screen

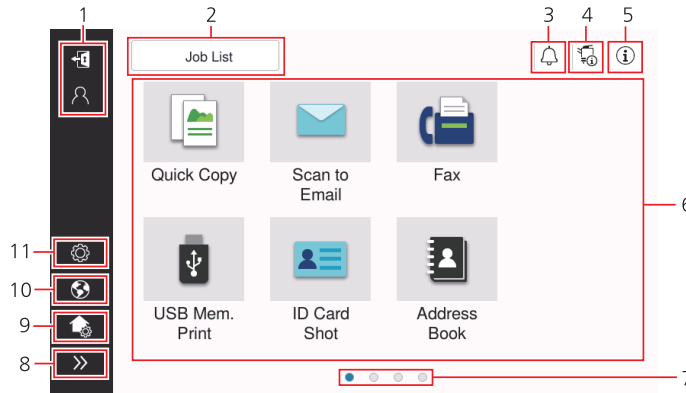
The layout of the home screen is as follows.



No.	Name	Descriptions
1	User/Account Name	Displayed when user authentication and account track are enabled. Opening the left area displays the name of the current login user or the account name. Tapping  logs out.
2	[Job List]	Displays active or standby jobs. If necessary, you can check job logs or print a communication report. This list displays the operation status of the current job on the [Job List] key when it is running. If necessary, you can stop the active job using the Stop key displayed next to the [Job List] key.
3	Notification icon	You can check warnings or notices related to the status of this machine.
4	Device information icon	You can check the current date and time, free space in memory, and toner level. The corresponding device information is displayed when: <ul style="list-style-type: none"> • A nonstandard USB flash drive is connected to this machine; • Device information logs are spooled; • Image logs are transferred; • This machine is in fax redial wait state; • This machine is receiving data; • This machine is sending data; • An E-mail server (POP) connection error occurs; or • The enhanced security mode is enabled.
5	Information icon	Displays a message for users.
6	Function key	Displays shortcut keys assigned to any function.
7	Page Indicator	You can check the currently displayed page number.

No.	Name	Descriptions
8	Left area open/close icon	Opens or closes the left area. Opening the left area displays the names of the icons in the left area.
9	[Customize Home screen]	Sets the function keys to display on the home screen.
10	[Language]	Temporarily changes the language to be displayed on the panel. This option is displayed when [Temporarily Change Language] is set to ON.
11	[Utility]	Configure settings of this machine or check the use status of this machine.

3. Login methods

When user authentication is enabled:

When user authentication is enabled on this machine, the login screen is displayed. Enter the user name and the password, and perform user authentication.

- ✓ The contents of the login screen may vary depending on the authentication setting of this machine.
- ✓ If Public User Access (unregistered users) is enabled, you can tap **[Used by public user]** on the login screen to operate this machine without authentication.

- 1** Enter the user name and password.

The screenshot shows a login interface with a dark header containing 'Login' and 'Job List' tabs, and a signal strength icon. Below the header, there is a link 'Used by public user>'. The main form area contains the following fields:

- ID & Print:** A dropdown menu currently showing 'Logout after Print'.
- Operation Rights:** A dropdown menu currently showing 'User'.
- User Name:** An empty text input field.
- Password:** An empty password input field.
- Server Name:** A text input field containing 'Main Unit'.

At the bottom of the form, there are two buttons: a grey 'Clear' button and a blue 'Login' button.

- 2** When **[Server Name]** is displayed, select the server to perform authentication.
 - The default authentication server is selected by default.
- 3** When **[Operation Rights]** is displayed, select the login user's operation privileges.
 - To log in as a registered user, select **[User]**.
 - To log in as an administrator, select **[Administrator]**.
 - To log in as a User Box administrator, select **[User Box Administrator]**.
- 4** When **[Authentication Method]** is displayed, select the authentication method.
- 5** Tap **[Login]**.

When authentication succeeds, you can operate this machine. The user name is displayed on the screen during login. If the login screen for account track is displayed, perform account track after this. For details on the account track operation, refer to page 21.

- 6** When the target operation is completed, select **[1]** to log out.
 - If this machine is left for a certain period of time during login (default: **[1]** min.), you are logged out automatically.

- 7 Tap **[Yes]** on the logout confirmation screen.

When account track is enabled:

When account track is enabled on this machine, the login screen is displayed. Enter the account name and the password to perform account track.

- ✓ The contents of the login screen may vary depending on the authentication setting of this machine.
- 1 Enter the account name and password.
 - When performing account track using only the password, the keypad is displayed on the login screen. If the password is numeral alone, it is possible to enter the password using the keypad. If the password contains a character, tap the **[Password]** entry area, and then enter the password.

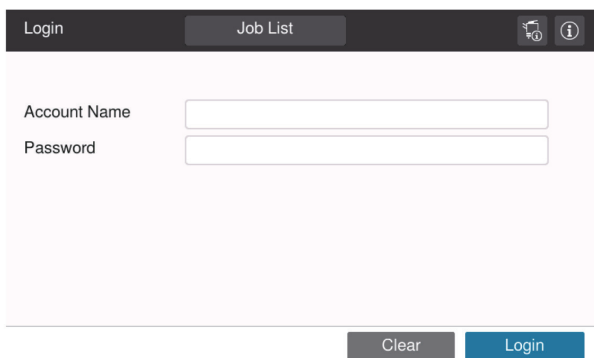

The screenshot shows a login interface with a dark header bar containing 'Login' and 'Job List' tabs, and a refresh icon. Below the header, there are two input fields: 'Account Name' and 'Password'. At the bottom, there are two buttons: 'Clear' and 'Login'.

- 2 Tap **[Login]**.

When authentication succeeds, you can operate this machine. The account name is displayed on the screen during the log in process. When user authentication and account track are enabled together, the user name is displayed on the screen.

- 3 When the target operation is completed, select **[1]** to log out.
 - If this machine is left for a certain period of time during login (default: [1] min.), you are logged out automatically.
- 4 Tap **[Yes]** on the logout confirmation screen.

D330E Series
Quick Start Guide

**Loading the Original
and Paper**

6

1. Load the original

The original loading methods are classified into two types: loading the original into the ADF (Automatic Document Feeder), and directly loading the original onto the Original Glass.

Select the appropriate one for your requirements.

1.1 Loading the original into the ADF

This function is useful when you want to scan an original containing multiple pages, or a sheet original of different sizes.

- Place original pages so that the first one is at the top.
- Load the original with the scanning side facing up.
- Slide the **Lateral Guide** to suit the original size.

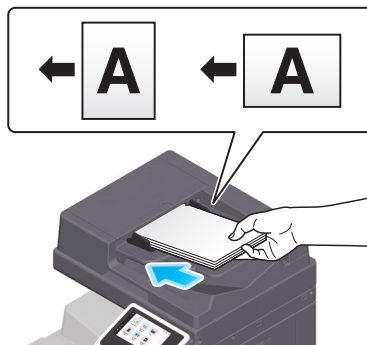

1.2 Placing the original on the Original Glass

This function is useful when you want to scan a small original such as a book, magazine, or business card.

- Place the original with the scanning side facing down.
- Align the original with the mark  at the left back of the **Original Glass**.



2. Loading paper

No paper setting is required because frequently used paper is loaded during general use. This section describes how to use paper that is not usually loaded into a paper tray. The methods for loading envelopes, postcards, label sheets, and index paper are as follows.

2.1 Loading paper in Tray 1 to Tray 2

Up to 500 sheets of plain paper can be loaded into each tray.

Applicable paper types

Plain paper, single-side-only paper, special paper, thick paper, letterhead, colored paper, recycled paper

How to load a paper

- 1 Pull out the tray.

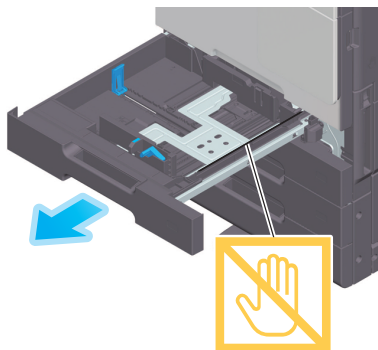

Notice

- Be careful not to touch the Film.

- 2 Slide the Lateral Guide to fit the size of the loaded paper.

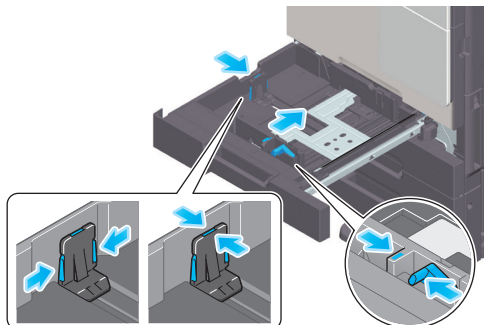

- 3 Load paper into the tray with the print side facing up.

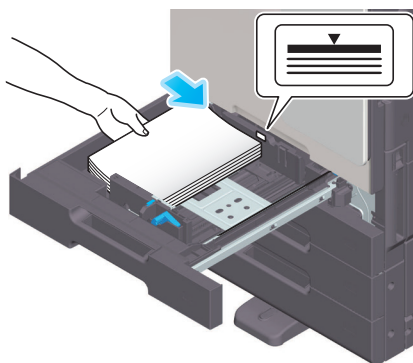

- 4 When loading paper other than plain paper, specify the paper type.
→ For details on how to specify the paper type, refer to the HTML User's Guide.

2.2 Loading paper into the Bypass Tray

When selecting a paper size other than for paper trays or printing on envelopes or transparencies, use the Bypass Tray. To use the Bypass Tray, specify the paper type and paper size.

Applicable paper types

Plain paper, single-side-only paper, special paper, thick paper, postcard (4 e 6 (A6 Card)), transparency, letterhead, colored paper, envelope, label sheets, index paper, recycled paper, and banner paper

How to load paper

- 1 Open the **Bypass Tray**.

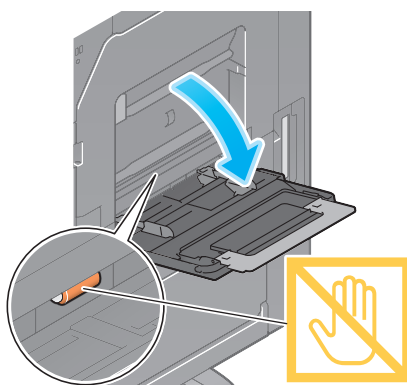

→ To load large-sized paper, pull out the **Tray Extension**.

Notice

- Be careful not to touch the surface of the Paper Feed Rollers with your hand.

- 2 Load paper with the print side facing down, then align the **Lateral Guide** to the paper.
 - Insert paper into the tray until their edges are pressed against the back.

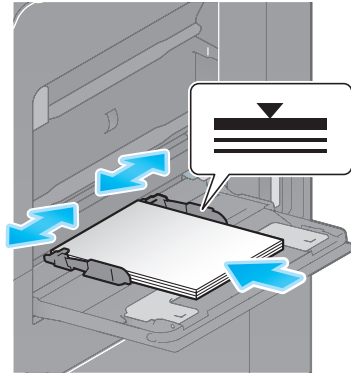

Notice

- Do not load an excessive number of sheets such that the top of the stack is higher than the ,
mark. If paper is curled, flatten it before loading it.
- 3 Specify the paper type and paper size.
 - For details on how to specify the paper type and paper size, refer to the HTML User's Guide.

2.3 Loading envelopes

Precautions when using envelopes

- Remove air from the envelope(s), and securely press along the flap fold line.
- Do not use envelopes that have glue or release paper on the flap or the part covered by the flap on the body.
- The flap side of envelopes cannot be printed on.
- When loading envelopes with flaps opened, also select the standard size that matches them. You do not have to measure the size of the envelope with the flap opened to set the size as a custom-sized envelope.

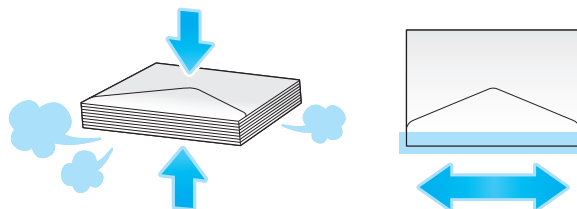

Up to 10 envelopes can be loaded into the tray.

- Move the Fusing Adjustment Lever up to the envelope position (top).
- Load envelopes with the flap part facing up.

6 Loading the Original and Paper

- Align the Lateral Guide with the envelope size.
- Select the desired envelope size from [Envelop/4 e6] ([Envelop/A6 Card]) of [Paper Size].\

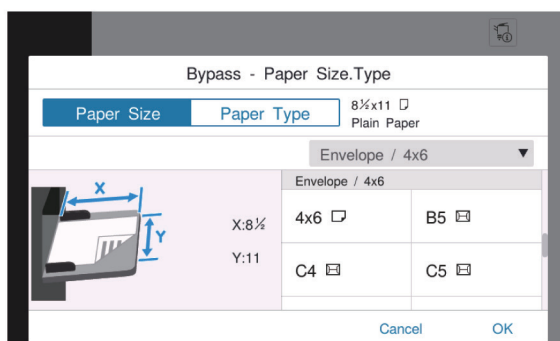
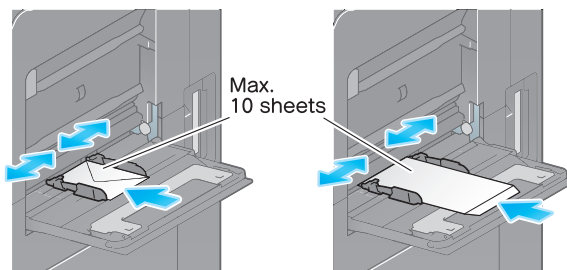
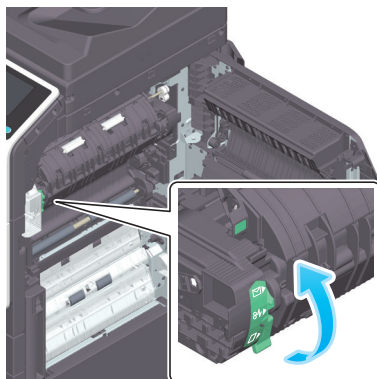

When envelope printing has been completed, return the **Fusing Adjustment Lever** to the normal printing position (bottom).

Caution

- **The inside of this product has areas subject to high temperature, which may cause burns. When checking the inside of the unit for malfunctions such as a paper misfeed, do not touch the locations (around the fusing unit, etc.) which are indicated by a "Caution HOT" caution label. A burn could result.**

2.4 Loading postcards

Precautions when using postcards

- When loading curled postcards, uncurl them.
- When using postcards other than 4 e 6 (A6 Card), confirm its size, and select **[Paper Size]** - **[Custom Size]** to specify the size.

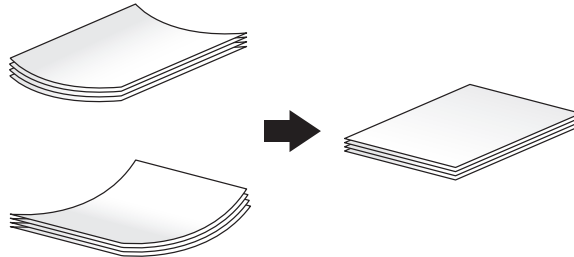

Up to 20 postcards can be loaded into the tray.

- Load postcards with the print side facing down.
- Align the Lateral Guide with the postcard size.
- Select the desired postcard size from **[Envelop/4x6]** (**[Envelop/A6 Card]**) of **[Paper Size]**.

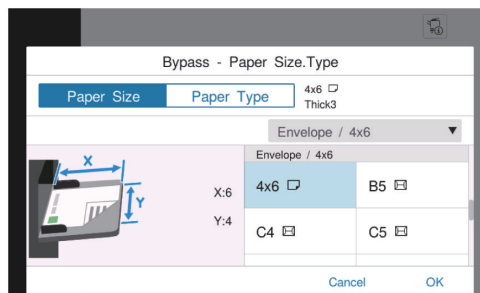
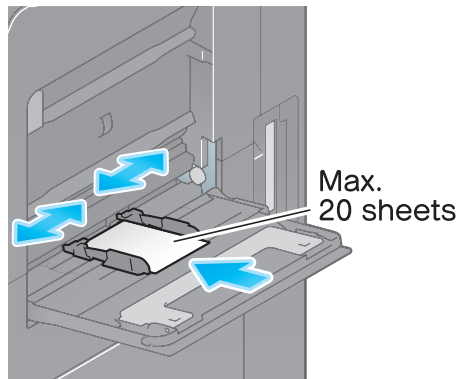

2.5 Loading label sheets

A label sheet consists of the front-side paper (print side), sticking layer, and pasteboard (template). Peel off the pasteboard, then you can stick the label to other objects. Up to 20 label sheets can be loaded into the tray.

- With the print side facing down, load label sheets as shown in the figure.
- Align the Lateral Guide with the label sheet size.
- Select **[Thick 1+]** from **[Paper Type]**.

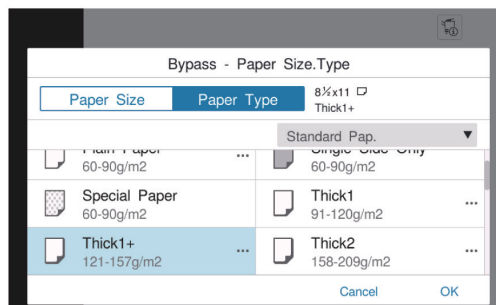
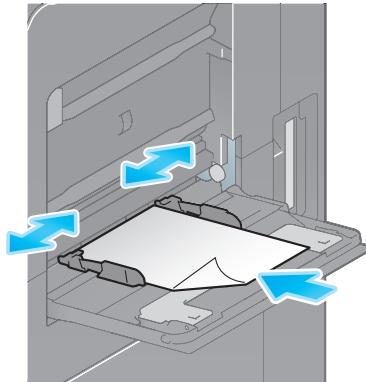

2.6 Loading index papers

Up to 20 index papers can be loaded into the tray.

- With the print side facing down, align the tab side as shown below.
- Align the Lateral Guide with the index sheet size.
- Select **[Index Paper]** from **[Paper Type]**.

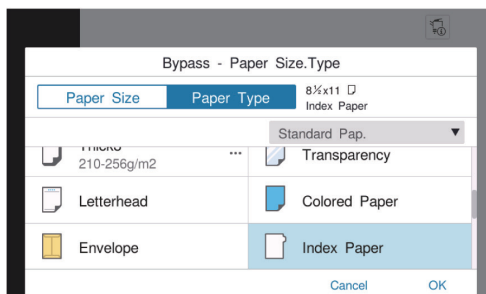
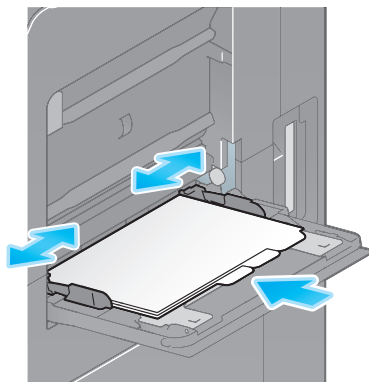

D330E Series
Quick Start Guide

**Available Operations
in this Machine**

7

This machine provides the copy function, print function, and scan/fax function as major functions. This section describes the basic operations for each function.

If you want to learn about more detailed descriptions or operation methods, refer to the HTML User's Guide included in the User's Guide CD.

1. How to copy

Basic copy operations

This section describes the basic copy operations.

- 1 If user authentication is enabled, the login screen appears.
Enter the required items, and tap **[Login]**.

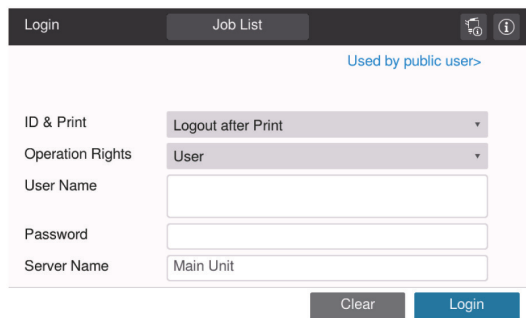

- 2 Load the original.

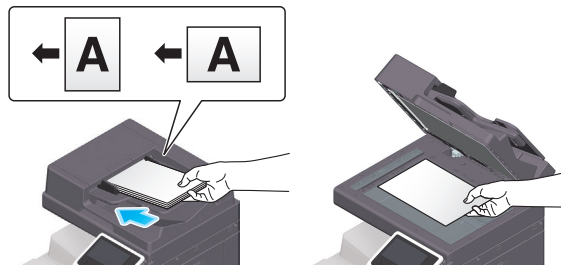

- 3 Tap **[Copy]** on the home screen.

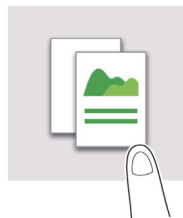

- 4 Set copy options as needed.

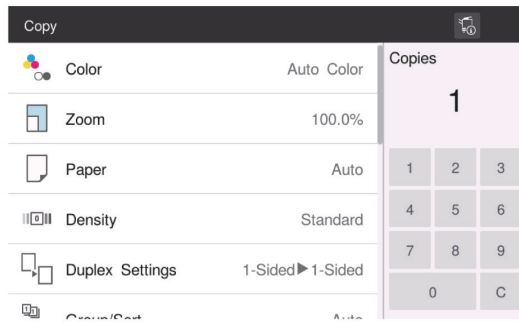

- 5 If necessary, specify the number of copies using the keypad.
- 6 Use the Start key to start copying.

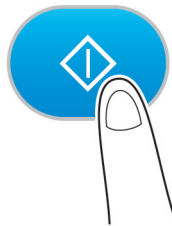

2. How to print

Basic print operations

This section describes the basic print operations.

- 1 Open document data using the application software. From the **[File]** menu, select **[Print]**.
- 2 Check the **[Printer Name]** (or **[Select Printer]**) make sure that the desired printer has been selected.
 - The **[Print]** dialog box differs depending on the application.

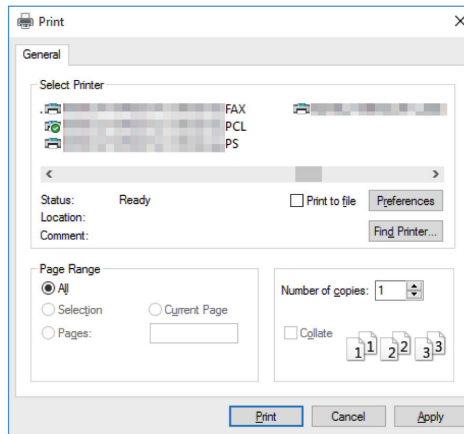

- 3 Specify the print range and the number of copies to print.
- 4 Click **[Properties]** (or **[Preferences]**) to change the print settings of the printer driver as necessary.
- 5 Click **[Print]**.



3. How to scan

Basic scan operations

This section describes the basic scan operations.

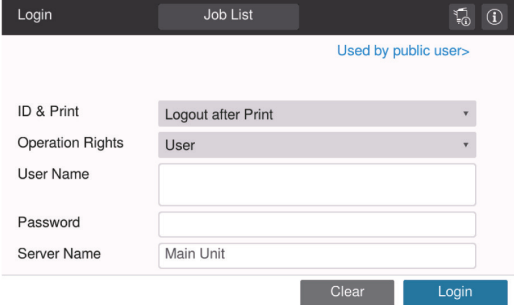
- 1 If user authentication is enabled, the login screen appears. Enter the required items, and tap **[Login]**.



Login Job List  

Used by public user>

ID & Print Logout after Print ▾

Operation Rights User ▾

User Name

Password

Server Name Main Unit

Clear Login

- 2 Load the original.

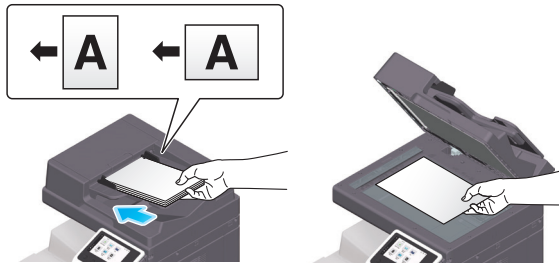

- 3 Tap the scan function key on the home screen.

- 4 Specify the destination.

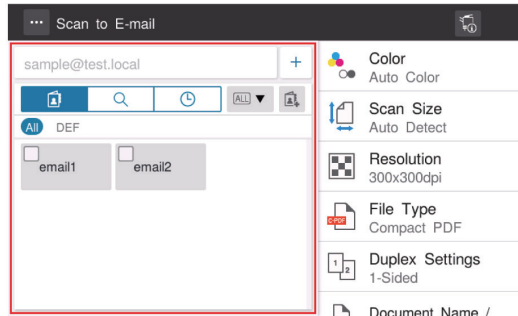

- 5 Specify transmission options as needed.

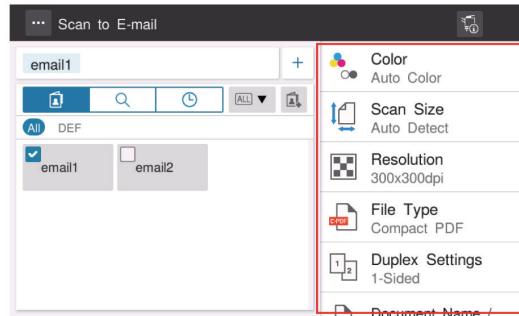

- 6 Use the Start key to start transmission.

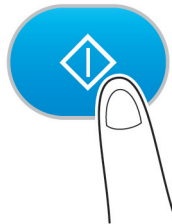

4. How to fax

Basic fax operations

This section describes the basic fax operations.

- 1 If user authentication is enabled, the login screen appears.
Enter the required items, and tap **[Login]**.

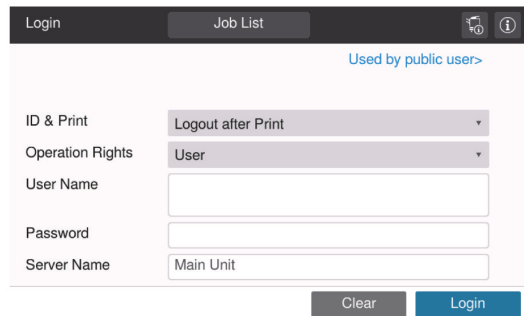

- 2 Load the original.

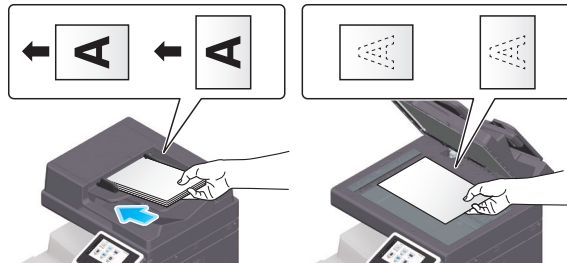

- 3 Tap **[Fax]** on the home screen.

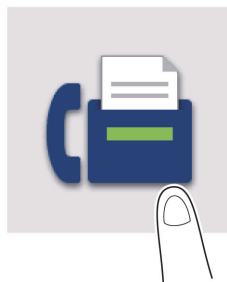

7 Available Operations in this Machine

- 4 Specify the destination.

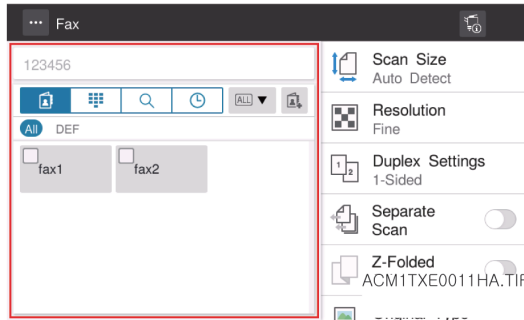

- 5 Specify transmission options as needed.

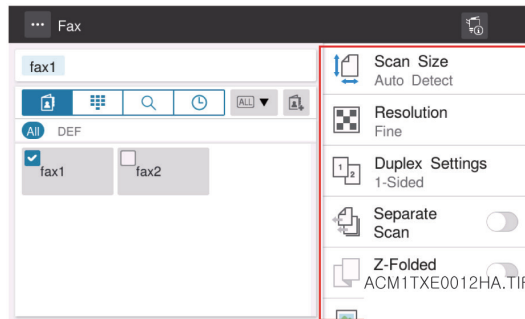

- 6 Use the Start key to start transmission.

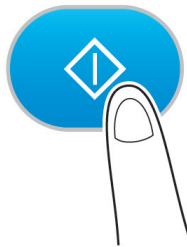

D330E Series
Quick Start Guide

**Registering
a Destination**

8

1. How to register a destination

Registering a fax address

- 1 Tap **[Utility]** - **[Utility]** - **[Store Address]** - **[Address Book]** - **[New Registration]**.
- 2 In **[Select Destination]**, select **[Fax]**.
- 3 Enter destination information.

Setting	Descriptions
[No.]	Destination registration number. Select [Use opening number] to automatically assign the smallest available number. When you want to specify a number, select [Input directly] and then enter a number.
[Name]	Enter the destination name (using up to 24 characters).
[Index]	Select an index to search for a destination using the registered name. For a frequently used destination, select the [Main] check box. The destinations are displayed on the destination selection screen, enabling the user to easily select a destination.
[Destination]	Enter the destination fax number (using up to 38 digits, including symbols #, *, -, and characters T, P, and E). <ul style="list-style-type: none"> • [T] or [*]: Enter the fax number when issuing a push signal in dial-up line mode (while [Dialing Method] is set to [10pps] or [20pps]). • [P]: Enter this when you want to insert a wait time between dials. • [-]: Enter this to separate a dial number. It does not affect the dialing of the number. • [E-]: Enter the registered outside line number in PBX environment. Enter this when [PBX Connection Setting] is set to ON.
[Confirm Fax Number]	Enter the fax number again. This option is displayed when [Function ON/OFF Setting] - [Confirm Address (Register)] is set to ON.
[Communication Setting]	If necessary, specify how to send a fax to a destination you want to register. You may change the settings you made here before sending a fax. <ul style="list-style-type: none"> • [V34 Off]: V.34 is a communication mode used for super G3 fax communication. When the remote machine or this machine is connected to a telephone line via PBX, however, you may not establish a communication in the super G3 mode depending on telephone line conditions. In this case, it is recommended that you turn the V.34 mode off to send data. • [ECM Off]: ECM is an error correction mode defined by ITU-T (International Telecommunication Union - Telecommunication Standardization Sector). Fax machines equipped with the ECM feature communicate with each other, confirming that the sent data is free of errors. This prevents image blurring caused by telephone line noise. The communication time can be reduced by setting ECM to OFF for transmission. However, an image error or communication error may occur depending on the specified communication time value, so change the value to suit conditions. • [International Communication]: Used to send a fax to areas where communication conditions are poor. Faxes are sent at a lower speed. • [Check Destination]: The fax number specified for fax is checked against the destination fax number (CSI) and the fax is sent only when they match.

4 Tap **[OK]**.

Registering E-mail address

1 Tap **[Utility] - [Utility] - [Store Address] - [Address Book] - [New Registration]**.

2 In **[Select Destination]**, select **[E-mail Address]**.

3 Enter destination information.

Setting	Descriptions
[No.]	Destination registration number. Select [Use opening number] to automatically assign the smallest available number. When you want to specify a number, select [Input directly] and then enter a number.
[Name]	Enter the destination name (using up to 24 characters).
[Index]	Select an index to search for a destination using the registered name. For a frequently used destination, select the [Main] check box. The destinations are displayed on the destination selection screen, enabling the user to easily select a destination.
[E-mail]	Enter the E-mail address of the destination (using up to 320 characters, excluding spaces).

4 Tap **[OK]**.

D330E Series
Quick Start Guide

**Read this if You Have
a Problem**

9

1. Main messages and remedies

1.1 Checking a notification message on the Touch Panel

The notification icon is displayed on the home screen when there is a machine condition warning or notice notification. You can tap the icon to check the notification contents.

- 1 Tap the notification icon on the home screen.

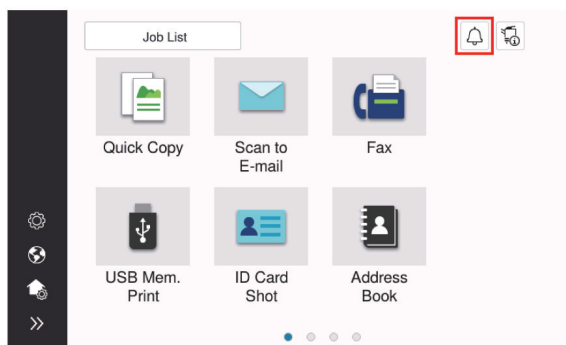

- 1 Tap [ATTENTION List], and check the notification list.

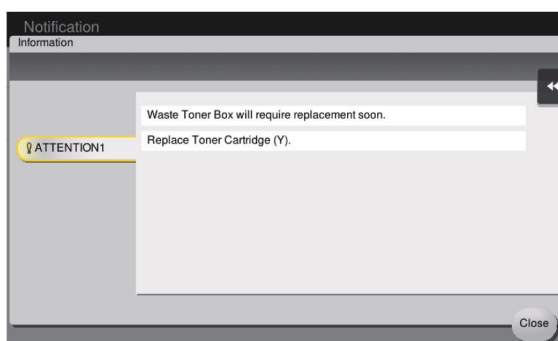

1.2 Screen that appears when a paper/staple jam has occurred

If any paper or staple jam occurs on this machine, the paper jam clearing procedure and the paper or staple jam location are displayed on the screen of this machine. Confirm the clear procedure and jam location, and follow the guidance to clear the jam.

If a paper jam is not cleared securely, the warning message is not reset. For details on how to take an action when a paper jam message is not reset, refer to the HTML User's Guide.

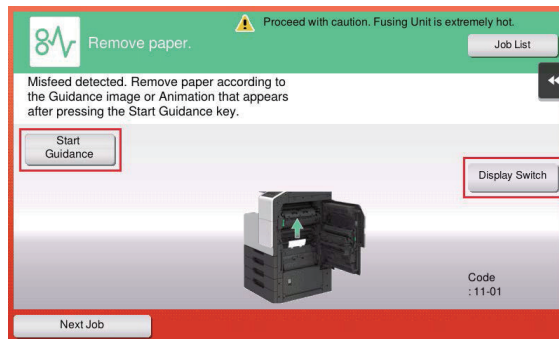

When a paper jam is cleared, a screen showing how to correctly load paper or the original is displayed.

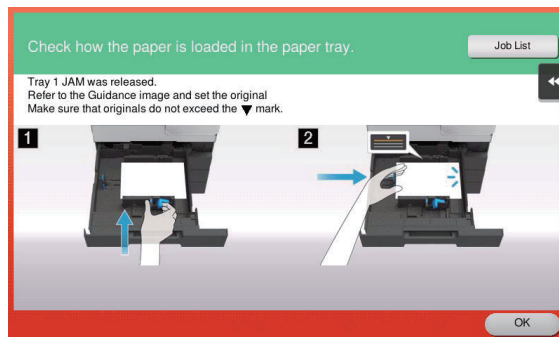

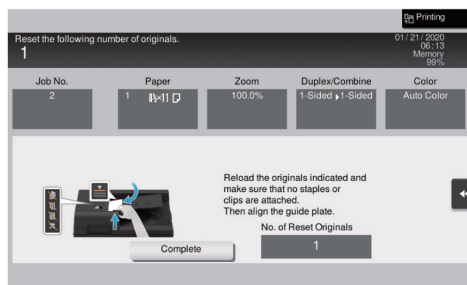

Return the original or paper, and tap **[OK]** or **[Complete]**; the system restarts scanning or printing of the original.

Item	Descriptions
[Start Guidance]	Starts the guidance showing how to clear a paper/staple jam.
[Display Switch]	Changes the screen that shows the paper jam clearing procedure and the screen that shows where the paper jam occurred.
Number (indicating the location number for the section with a paper/staple jam)	A section chart is displayed with a location number enclosed in a circle for a section where a paper/staple jam has occurred.

1.3 When an error message appears

When an error is detected, the following message appears. Take the appropriate action according to the message displayed on the screen. If you cannot resolve the error, write down the **[Trouble Code]**, and contact your service representative with the power plug disconnected from the power outlet. In normal circumstances, the phone number and fax number for your service representative appear in the center of the screen.

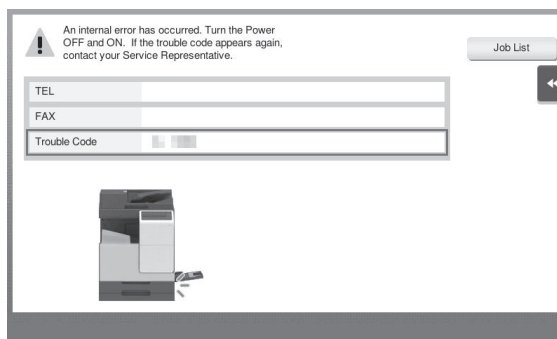

Notice

- If a defective part can be separated in order to be able to continue operations after a problem has been detected, **[Continue]** or **[Recover Data]** is displayed. To continue operations, select any key. However, the problem has not been resolved, so contact your service representative immediately.

2. When the Touch Panel is not visible

If a certain length of time has elapsed without any operations being carried out on this machine, the **Touch Panel** may turn off.

Check the following items:

- Touch the Touch Panel. In Power Save (Low Power/Sleep) mode, this machine returns from Power Save mode when the Touch Panel is touched or a key on the Control Panel is pressed, and the Touch Panel appears normally.

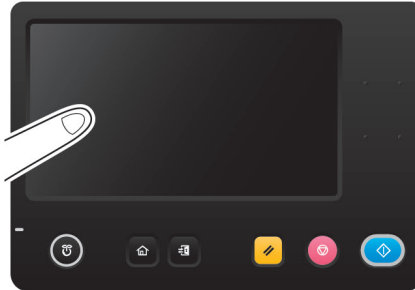

- On the **Control Panel**, press the **Power** key. If the Weekly Timer setting has put the machine in Erp Auto Power off mode, press the Power key to display the **Touch Panel**. To use it outside the preset operating hours, follow the on-screen instructions.



- Check to see that the **Main Power Switch** is turned ON.

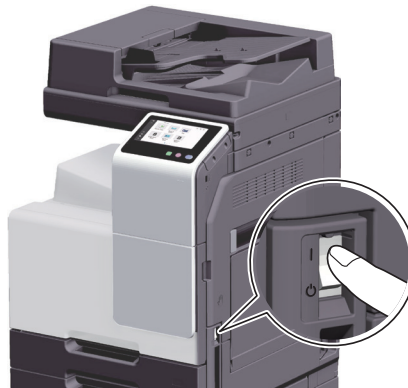

3. When printing quality has deteriorated

Cleaning the Original Glass and roller

Wipe the surface using a soft, dry cloth.

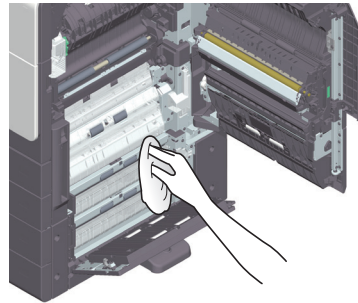
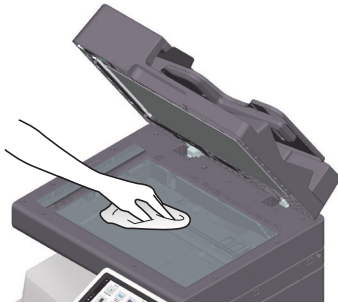

⚠ Caution

- The inside of this product has areas subject to high temperature, which may cause burns. When checking the inside of the unit for malfunctions such as a paper misfeed, do not touch the locations (around the fusing unit, etc.) which are indicated by a “Caution HOT” caution label. A burn could result.

Cleaning the Slit Scan Glass

- ✓ Perform this procedure when the **Reverse Automatic Document Feeder DF-633** is installed on the machine.

- 1 Open the **ADF**.

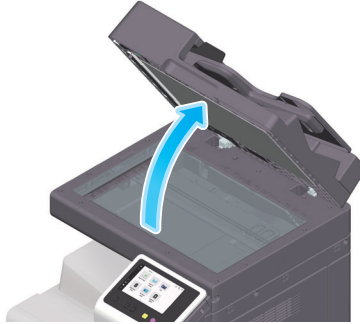

- 2 Wipe stains off the **Slit Scan Glass** using a dry, clean cloth.

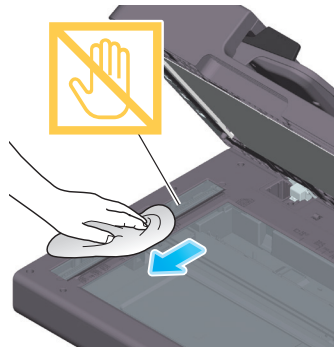

Notice

- Do not touch the Slit Scan Glass.

Cleaning the Print Head Glass

Printing quality deteriorates if the Print Head Glass is dirty. If this occurs, clean the Print Head Glass according to the following procedure.

- 1 Open the **Front Door** of the machine.

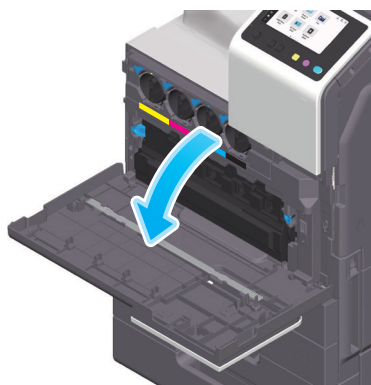

- 2 Remove the Waste Toner Box.

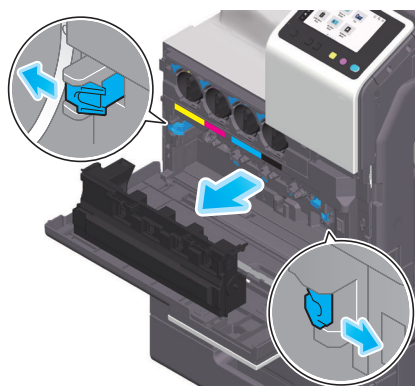

- 3 Remove the **Printhead Cleaner** from the **Front Door** of this machine.

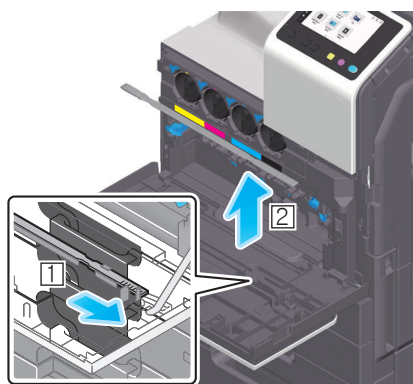

- 4** Slowly insert the **Printhead Cleaner** all the way to the back end of the **Print Head Glass**, and then slowly pull it out.
→ Repeat this operation approximately three times for all the **Print Head Glass** sections.

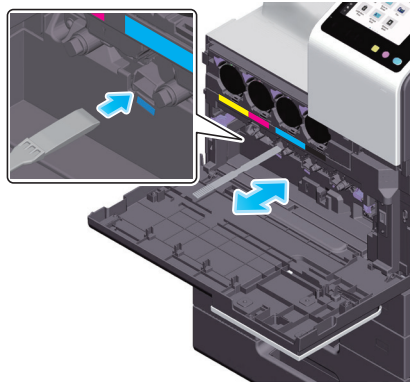

- 5** Mount the **Printhead Cleaner** onto the **Front Door** of this machine.
- 6** Mount the **Waste Toner Box**.
- 7** Close the **Front Door** of the machine.

4. When a message appears to replace consumables or carry out cleaning

A message appears indicating the time(s) that expiring consumables used in this machine should be replaced. Also, a message appears when the **Slit Scan Glass** is dirty.

Replace consumables or clean the **Slit Scan Glass** as instructed in the displayed message. Contact your service representative if the messages continue to appear even after replacement or cleaning has been carried out.

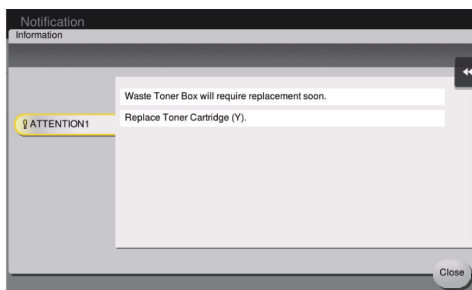

4.1 About Developing Unit

When it is time to replace a **Developing Unit**, a message appears to prompt you to contact your service representative. If the message appears, contact your service representative.

Tips

- The settings by the service representative are required to display a message about **Developing Unit**. By the factory default status, this message is displayed only in some area. For details, contact your service representative.

4.2 About Imaging Unit

When it is time to replace an **Imaging Unit**, a message appears to prompt you to contact your service representative. If the message appears, contact your service representative.

Tips

- The settings by the service representative are required to display a message about **Imaging Unit**. By the factory default status, this message is displayed only in some area. For details, contact your service representative.

4.3 About Drum Unit

When it is time to replace a **Drum Unit**, a message appears to prompt you to contact your service representative. If the message appears, contact your service representative.

Tips

- The settings by the service representative are required to display a message about **Drum Unit**. By the factory default status, this message is displayed only in some area. For details, contact your service representative.

Replacing a Drum Unit

The **Drum Unit** only for black is targeted for replacement.

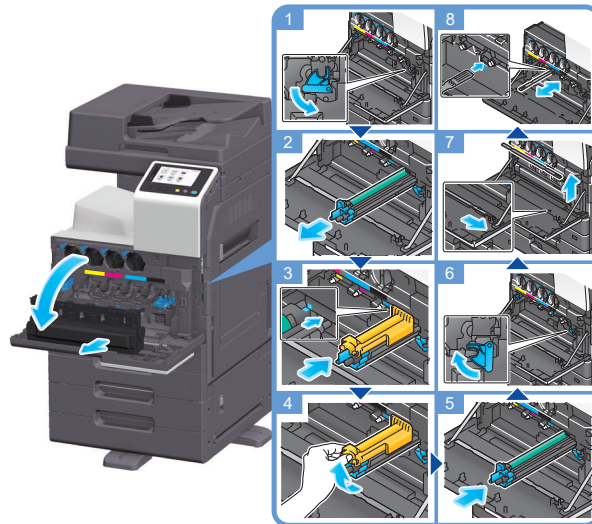

Unpacking the Drum Unit

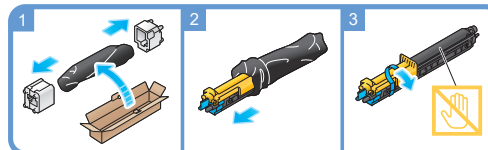

Tips

- Your service representative will collect your used **Drum Unit**. Put it in a black plastic bag and store it in a box by itself.
- A **Drum Unit** may be damaged due to exposure to light. Do not take it out of a black plastic bag until just before it is to be installed.
- After replacing a **Drum Unit**, be sure to clean the **Print Head Glass** for each color. For details on how to clean the **Print Head Glass**, refer to page 38.

Warning

- **Do not throw toner or a container that contains toner (e.g., toner cartridge, developing unit and Waste Toner Box) into an open flame. The hot toner may scatter and cause burns or other damage.**

⚠ Caution

- Do not leave toner-related parts (e.g., toner cartridge, developing unit and Waste Toner Box) within easy reach of children. Licking any of these parts or ingesting toner could damage your health.
- Do not store toner-related parts (e.g., toner cartridge, developing unit and Waste Toner Box) near devices susceptible to magnetism, such as precision equipment and data storage devices, otherwise they may malfunction. They could cause these products to malfunction.
- Do not force open the toner-related parts (e.g., toner cartridge, developing unit and Waste Toner Box). If toner tumbles from the toner bottle, take utmost care to avoid inhaling it or even getting skin contact.
- If toner lands on your skin or clothing, wash thoroughly with soap and water.
- If you inhale toner, move to a place with fresh air and gargle with a lot of water repeatedly. Should you get symptoms such as coughing, seek medical advice.
- If you get toner into your eyes, immediately rinse them with running water for over 15 minutes. Seek medical advice if irritation persists.
- If you swallow toner, rinse out your mouth and drink a few glasses of water. Seek medical advice if necessary.

4.4 About Toner Cartridge

When toner is running out in the Toner Cartridge

When it is almost time to replace a **Toner Cartridge**, an advanced warning message appears. Prepare a Toner Cartridge for replacement based on the maintenance contract.

When it is time to replace a Toner Cartridge

When it is time to replace a **Toner Cartridge**, a replacement prompt message appears. Replace it based on the maintenance contract. You can display the replacement procedure on the screen and check it.

⚙ Tips

- Do not replace a Toner Cartridge of a color that is not displayed.

Replacing a Toner Cartridge

The following example shows how to replace a Yellow Toner Cartridge.

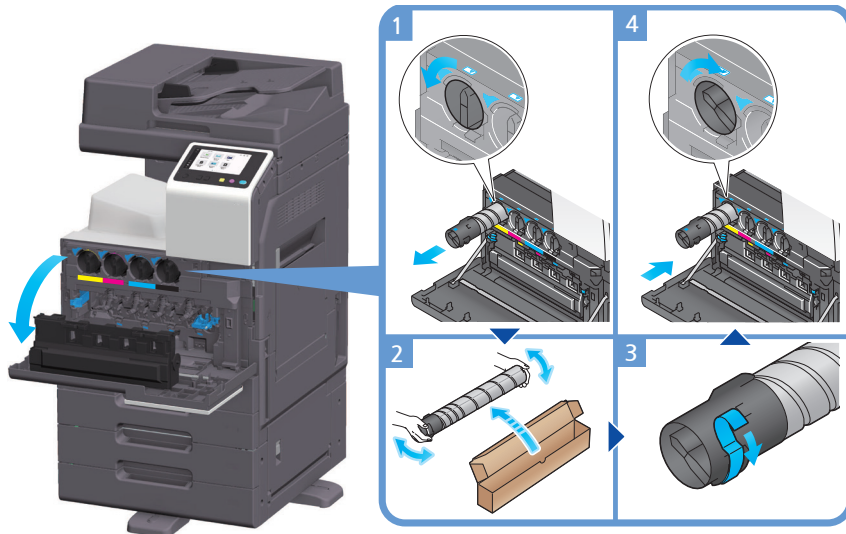

Tips

- Shake a new Toner Cartridge well, approximately 5 to 10 times, before installing it.
- If a toner cartridge other than for black is empty, printing can be continued forcibly using black. Tap **[Continue]**, and then select a desired print job.
- Do not forcibly open or disassemble a Toner Cartridge (toner container).
- Do not forcibly remove or dispose of toner that remains in a Toner Cartridge (toner container).

Notice

- Install a Toner Cartridge for each label color. If you try to forcibly install a Toner Cartridge in the incorrect position, it may result in a failure.

Warning

- **Do not throw toner or a container that contains toner (e.g., toner cartridge, developing unit and Waste Toner Box) into an open flame. The hot toner may scatter and cause burns or other damage.**

⚠ Caution

- Do not force open the toner-related parts (e.g., toner cartridge, developing unit and Waste Toner Box). If toner tumbles from the toner bottle, take utmost care to avoid inhaling it or even getting skin contact.
- If toner lands on your skin or clothing, wash thoroughly with soap and water.
- If you inhale toner, move to a place with fresh air and gargle with a lot of water repeatedly. Should you get symptoms such as coughing, seek medical advice.
- If you get toner into your eyes, immediately rinse them with running water for over 15 minutes. Seek medical advice if irritation persists
- If you swallow toner, rinse out your mouth and drink a few glasses of water. Seek medical advice if necessary.

⚠ Caution

- Do not leave toner-related parts (e.g., toner cartridge, developing unit and Waste Toner Box) within easy reach of children. Licking any of these parts or ingesting toner could damage your health.
- Do not store toner-related parts (e.g., toner cartridge, developing unit and Waste Toner Box) near devices susceptible to magnetism, such as precision equipment and data storage devices, otherwise they may malfunction. They could cause these products to malfunction.

4.5 About Waste Toner Box

When the **Waste Toner Box** is full, a message appears to prompt you to replace it (at replacement by user). Follow the displayed guidance to take an action.

Replacing a Waste Toner Box

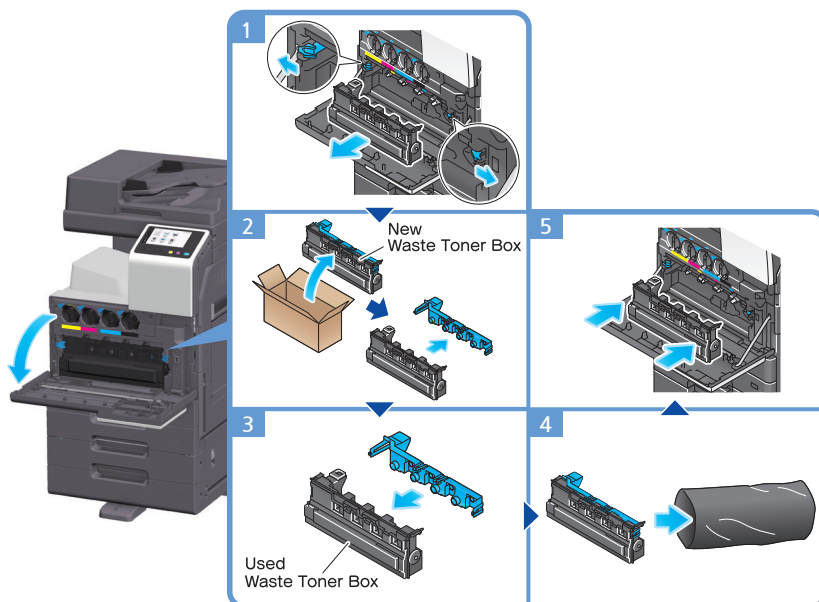

 **Tips**

- After removing the Waste Toner Box, quickly install the cap. If the Waste Toner Box is tilted, waste toner may spill.
- Your service representative will collect your used Waste Toner Box. Put it in a plastic bag, and store it in a box by itself.

 **Warning**

- **Do not throw toner or a container that contains toner (e.g., toner cartridge, developing unit and Waste Toner Box) into an open flame. The hot toner may scatter and cause burns or other damage.**

 **Caution**

- **Do not leave toner-related parts (e.g., toner cartridge, developing unit and Waste Toner Box) within easy reach of children. Licking any of these parts or ingesting toner could damage your health.**
- **Do not store toner-related parts (e.g., toner cartridge, developing unit and Waste Toner Box) near devices susceptible to magnetism, such as precision equipment and data storage devices, otherwise they may malfunction. They could cause these products to malfunction.**
- **Do not force open the toner-related parts (e.g., toner cartridge, developing unit and Waste Toner Box). If toner tumbles from the toner bottle, take utmost care to avoid inhaling it or even getting skin contact.**
- **If toner lands on your skin or clothing, wash thoroughly with soap and water.**
- **If you inhale toner, move to a place with fresh air and gargle with a lot of water repeatedly. Should you get symptoms such as coughing, seek medical advice.**
- **If you get toner into your eyes, immediately rinse them with running water for over 15 minutes. Seek medical advice if irritation persists.**
- **If you swallow toner, rinse out your mouth and drink a few glasses of water. Seek medical advice if necessary.**

4.6 About Staple Cartridge

When staples in the **Finisher** have run out, a message appears to prompt you to make replenish them. Take action while referring to the label inside the machine.

Replacing a Staple Cartridge (for Finisher FS-539 / Finisher FS-539 SD)

- 1 Open the **Front Door** of the **Finisher**.

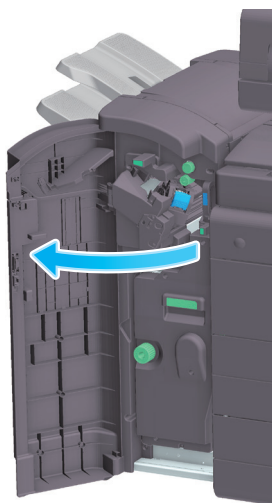

- 2 Unlock the **Staple Cartridge**.

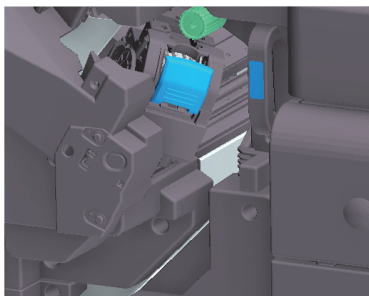

- 3 Pull out the **Staple Cartridge**.

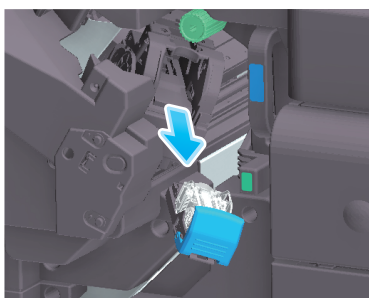

- 4 Remove any empty staple cases from the **Staple Cartridge**.

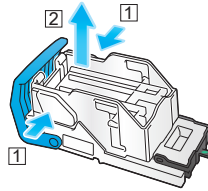

- 5 Attach a new staple case to the **Staple Cartridge**.

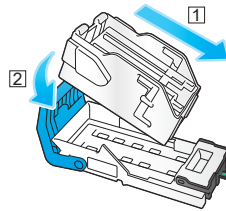

- 6 Attach the **Staple Cartridge**.

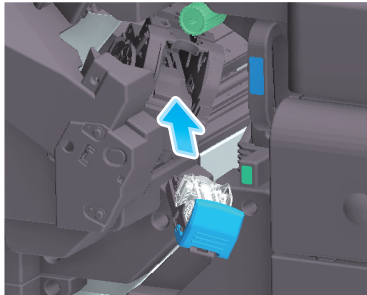

- 7 Close the **Front Door** of the **Finisher**.

Tips

- Do not remove staples that remain in the machine. Otherwise, the stapling function will activate but no sheets will be stapled.

Notice

- Be sure to replace the Staple Cartridge after the relevant message has appeared. If a Staple Cartridge is removed before the relevant message appears, it may result in a failure.

Replacing a Staple Cartridge (for Finisher FS-533)

- 1** Pinch the **Lock Release Lever**, and slide the Finisher.

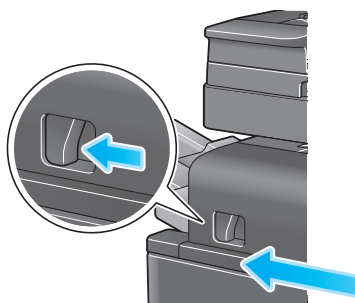

- 2** Pull the **Punch Kit Release Lever [FS2]** in the arrow direction, and open the Punch Kit.

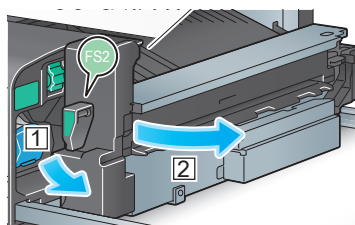

- 3** Unlock the **Staple Cartridge**.

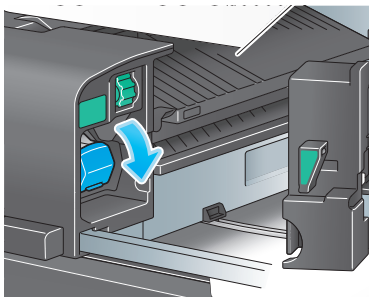

- 4** Pull out the **Staple Cartridge**.

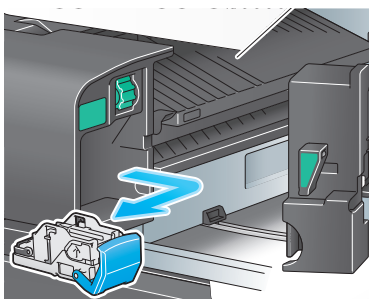

- 5 Remove any empty staple cases from the **Staple Cartridge**.

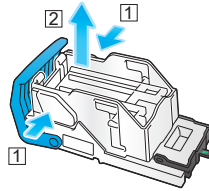

- 6 Attach a new staple case to the **Staple Cartridge**.

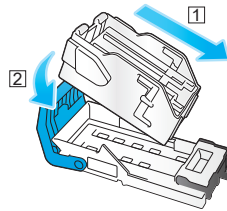

- 7 Attach the **Staple Cartridge**.

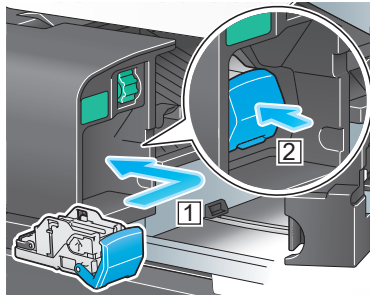

- 8 Close the **Punch Kit**.

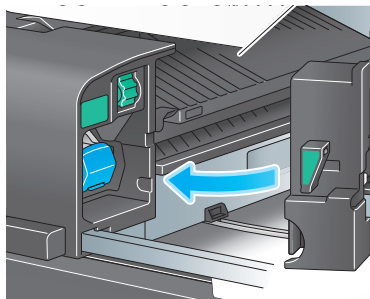

- 9 Close the **Finisher**.

Tips

- Do not remove staples that remain in the machine. Otherwise, the stapling function will activate but no sheets will be stapled.

Notice

- Be sure to replace the Staple Cartridge after the relevant message has appeared.
If a Staple Cartridge is removed before the relevant message appears, it may result in a failure.

Replacing a Saddle Staple Cartridge (for Finisher FS-539 SD)

- 1 Open the **Front Door** of the **Finisher**.

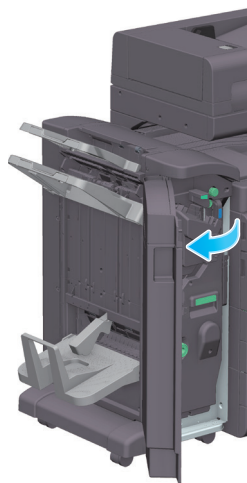

- 2 Pull out the **Saddle Stitcher**.

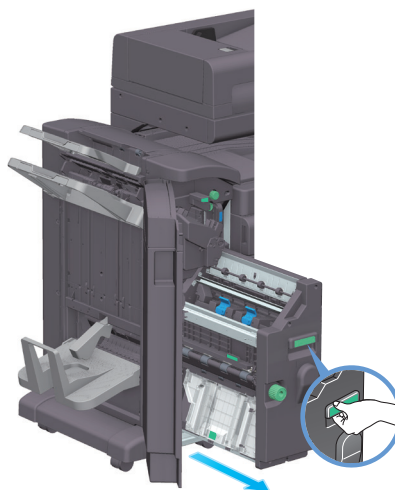

- 3 Tilt the blue knob of the **Saddle Staple Cartridge** toward you.

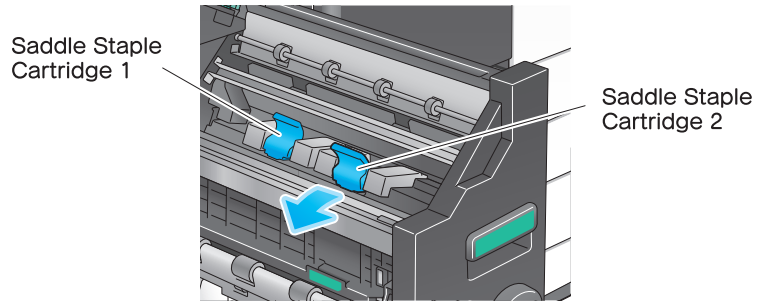

- 4 Pull out the **Saddle Staple Cartridge**.

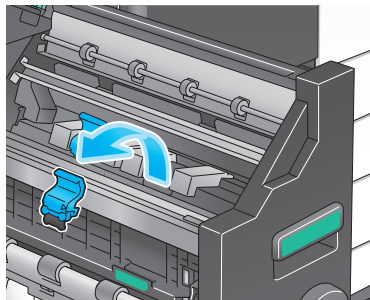

- 5 Open the **Saddle Staple Cartridge** cover.

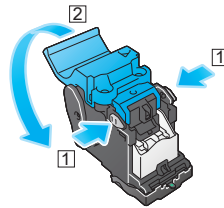

- 6 Remove any empty staple cases from the **Saddle Staple Cartridge**.

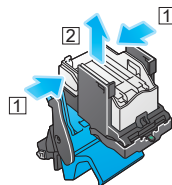

9 Read this if You Have a Problem

- 7** Attach a new staple case to the **Saddle Staple Cartridge**.

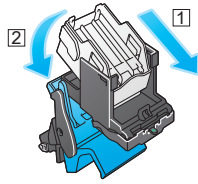

- 8** Close the **Saddle Staple Cartridge** cover.

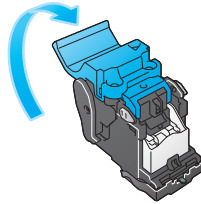

- 9** Attach the **Saddle Staple Cartridge**.

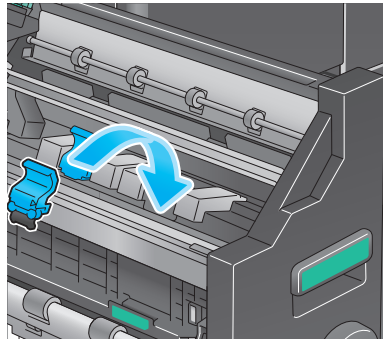

- 10** Push the blue knob of the **Saddle Staple Cartridge** to the back.
→ Check that the mark of the Saddle Staple Cartridge matches that of the Saddle Stitcher.

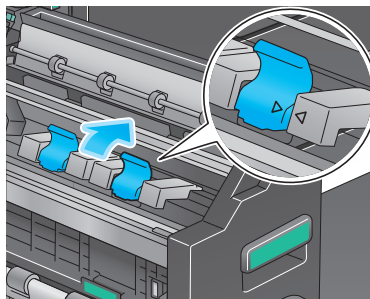

- 11** Push in the **Saddle Stitcher**.

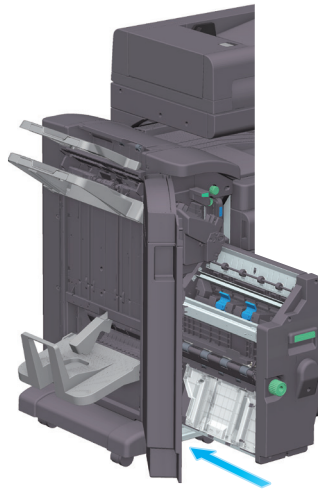

- 12** Close the Front Door of the **Finisher**.

 **Tips**

- Do not remove staples that remain in the machine. Otherwise, the stapling function will activate but no sheets will be stapled.

 **Notice**

- When moving the Saddle Stitcher, be sure to only hold the handle. Otherwise, your hand or finger may get caught in the machine. Be sure to replace the Saddle Staple Cartridge after the relevant message has appeared. If a Saddle Staple Cartridge is removed before the relevant message appears, it may result in a failure.

4.7 About hole-punch scraps

When the punch scrap box is full, a message appears to prompt you to dispose of the punch scraps (at replacement by user). Take action while referring to the label inside the machine.

Punch scrap processing (for Finisher FS-539 / Finisher FS-539 SD)

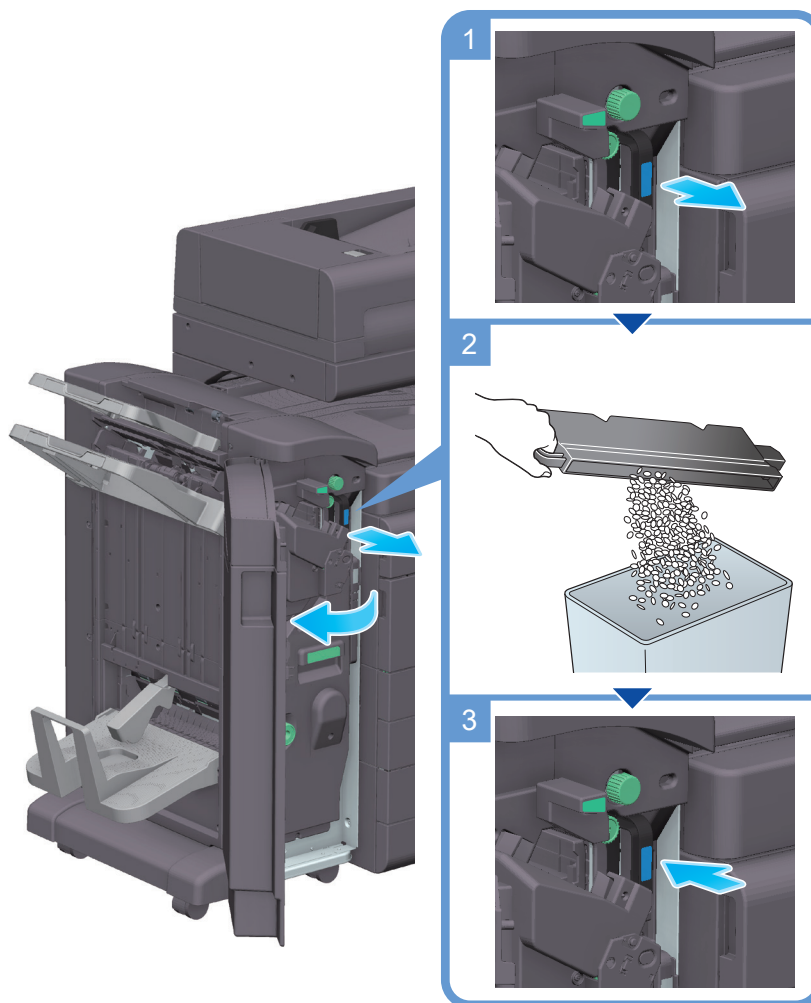

 **Tips**

- The figure shows the Finisher FS-539 SD equipped with Punch Kit PK-524 and Relay Unit RU-514.

Punch scrap processing (for Finisher FS-533)

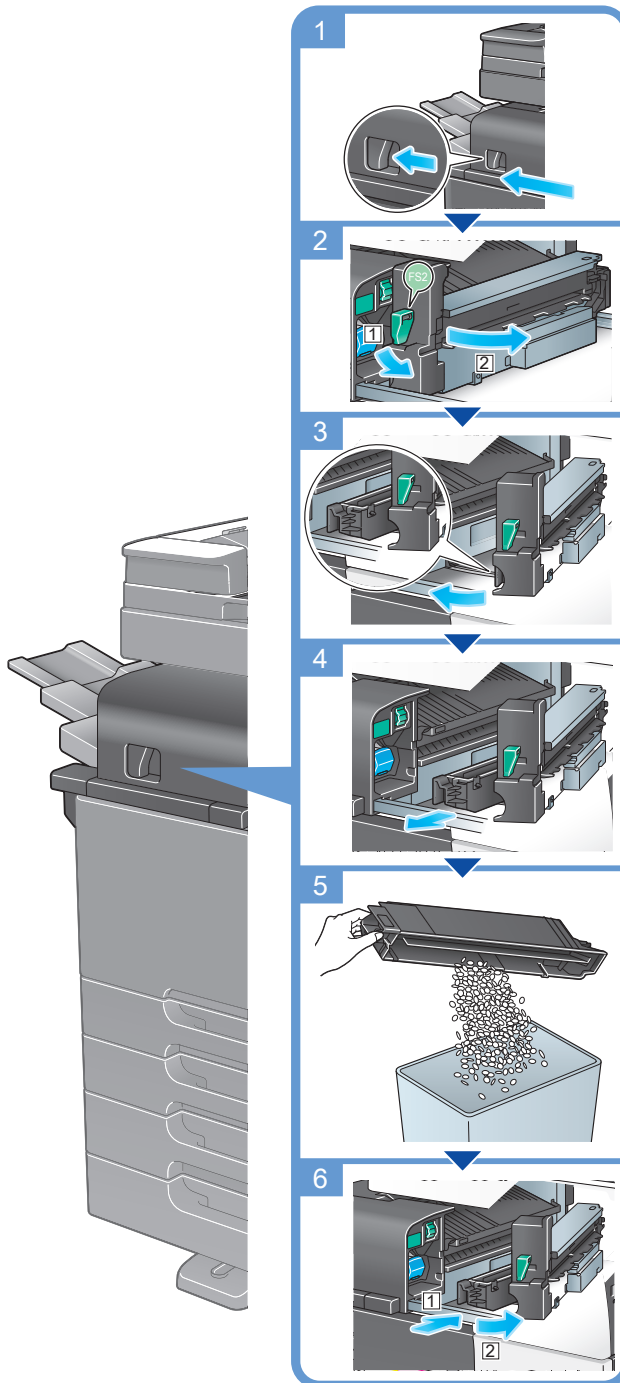

Tips

- The figure shows the Finisher FS-533 equipped with Punch Kit PK-519.

Warranty Conditions (D330E, D331E, D332E / D330A, D331A, D332A)

- The term of the warranty for the Machine of this product is 1 (one) year, and the quantity under warranty is 60,000 sheets. Warranty expires, when machine's real-time usage overruns quantity under warranty during the warranty period.

※ Average Use Quantity: The average use quantity is calculated based on the ordinary regular checkup (Under the Standard mode)

D330E/D330A : 4,000 sheets/month D331E/D331A : 4,200 sheets/month D332E/D332A : 5,700 sheets/month

Standard Mode Base					
Item		D330E/D330A	D331E/D331A	D332E/D332A	
Print	Color	1.5 Page/Job	1.5 Page/Job	2 Page/Job	
	Black	3 Page/Job	3 Page/Job	3 Page/Job	
Paper Ratio		A4 : 93% , A4S : 7%			
Color Ratio		30% (Based on 5% for each color)			
Average Print Volume (1 month)		4,000 sheet	4,200 sheet	5,700 sheet	

※ The above value can will vary and be affected by the density of your print jobs and other factors.

※ 3Page / Job : The condition of printing 3 pages per job(The actual yield on the consumables will vary and be affected by the proportion of different printing jobs.)

- Please refer to below chart for replacement cycle of consumables and maintenance parts (unit : sheets)

Item		D330E/D330A	D331E/D331A	D332E/D332A	Remark
Toner	Cyan	24,000			Based on Standard mode
	Magenta	24,000			
	Yellow	24,000			
	Black	24,000			
Developing Unit (Black)		600,000			
Drum Unit (Black)		80,000	102,000	105,000	
Color Imaging Unit		70,000	87,000	90,000	
Transfer Belt		300,000			
Transfer Roller Unit		300,000			
Fusing Unit		500,000			
Tray Pickup/Feeding/Separation Roller		300,000			
ADF Pickup/Feeding/Separation Roller		200,000			
Waste Toner Box		24,000	28,000	28,000	

※ Since the above replacement items are based on the standard mode in general use environment, the error of the replacement time may occur.

※ Please follow the replacement cycle since the above replacement items give direct impact.

※ The items (general parts) out of the above items should be checked up for the need or fault. If a trouble arises, the actions taken by professional engineer will be required

※ The warranty on consumables and maintenance parts is applied based on the replacement standard which is calculated from replacement cycle within the terms of warranty.

※ The warranty is processed in accordance with the claim process and standard by Sindoh.

Notice to users

Type	Notice
<ul style="list-style-type: none">• Class A items (Broadcast communications unit for business use)	This class A product is registered in Electromagnetic Compatibility, and User may be required to take adequate measures for other purposes than household use.
<ul style="list-style-type: none">• Class B items (Broadcast communications unit for household use)	This class B product is registered in Electromagnetic compatibility and is for domestic environment and also for general use.

- ※ This device is Class A Equipment in North America.
- ※ This device is Class B Equipment in other countries.



ACM19584



Printed in China