

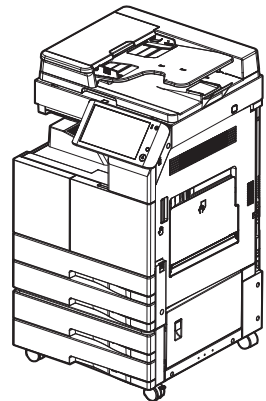

## N620/MF Series

Wifi Kit 설치 안내서  
Wifi Kit 设置顺序书  
Wifi Kit Installation Guide



# N620WN

## Wifi 설치장치/Wifi Kit 설치 수순서

적용 제품 : N620/MF Series

### 1. 동봉품

No.	이름	모양	수량
1.	Wifi 모듈		1
2.	클램프		5
3.	케이블		1

\* 판매 지역에 따라 변동이 있을 수 있습니다.

### ⚠ 경고



개봉 후 포장제를 제거하고 어린이의 손이 닿지 않는 곳에 보관하십시오. 비닐 봉투에 머리를 집어넣는 것은 질식의 위험을 일으킵니다.

### 📖 노트

- 설치수순서는 동봉품과 기기에 대한 설명을 포함하고 있으나 설치 수순서에 기재된 사진들은 실물과 약간의 차이가 있을 수 있습니다. 이 경우, 설치 수순서에서 기재된 사진 대신 가지고 계신 부품을 이용하여 설치 수순에 따라 작업을 진행하시면 큰 변동이나 문제 없이 설치를 마무리 지을 수 있습니다.

### 2. 설치 절차

- 1 기기의 전원을 끄고, 전원 코드를 분리합니다.
- 2 옵션 박스를 개봉하고, 부품의 수량 및 이상 유무를 확인합니다.
- 3 Wifi 모듈(1번 부품)과 케이블(3번 부품)을 그림과 같이 조립합니다.

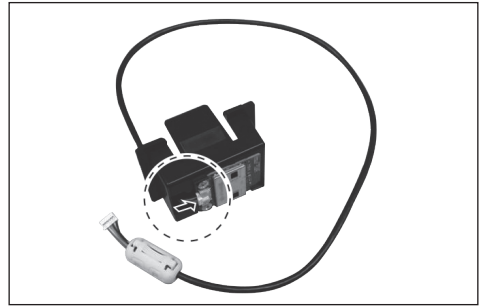

- 4 본체의 뒷커버(나사 14개)를 분리합니다.

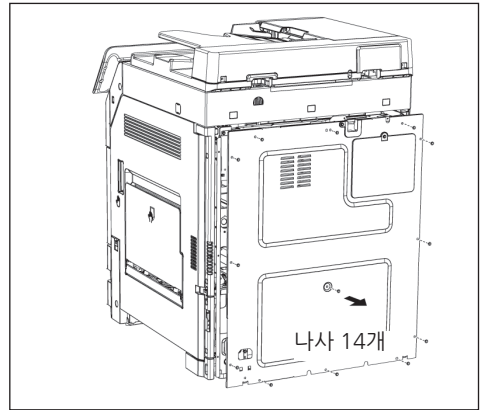

- 5 본체의 왼쪽면 커버(나사 6개)를 분리합니다.

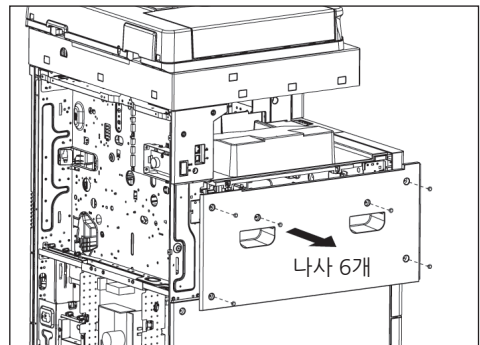

**6** 본체 안쪽의 프레임(나사 4개)을 분리합니다.

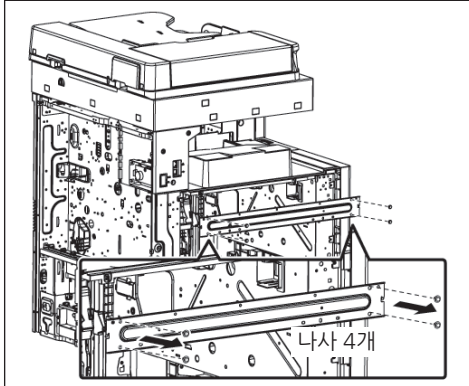

**7** 6 번 수순에서 분리한 프레임 안쪽 면에 클램프 (2번 부품, 3개)을 설치합니다.

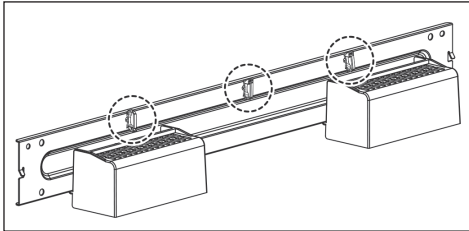

**8** 본체에 클램프(2개)를 설치합니다.

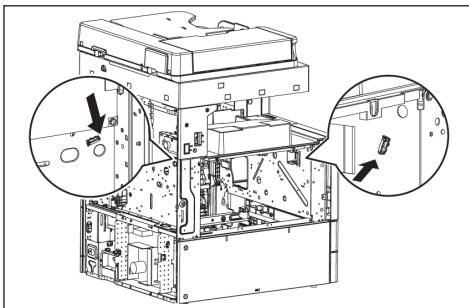

**9** 기기에 Wifi 모듈을 장착하고 클램프로 그림처럼 고정 시킵니다.

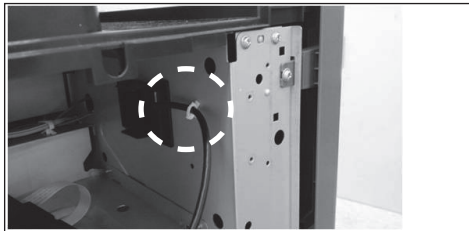

**10** 케이블을 기기의 뒷편으로 그림의 구멍을 통해 나오도록 합니다.

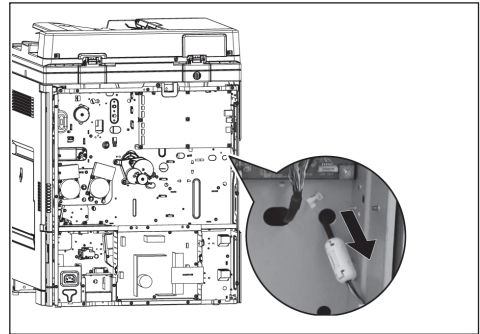

**11** Wifi 모듈의 케이블을 6 번 수순에서 분리한 프레스물의 클램프로 체결 후 본체에 조립합니다.

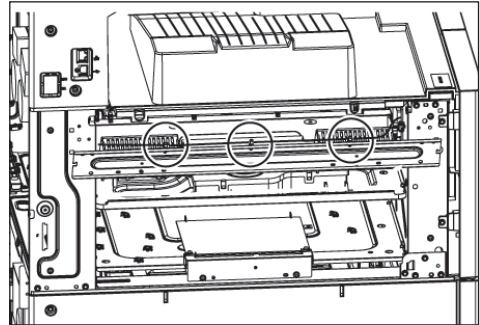

**12** 기기 뒷편의 클램프로 케이블을 체결 후 본체 보드와 연결합니다.

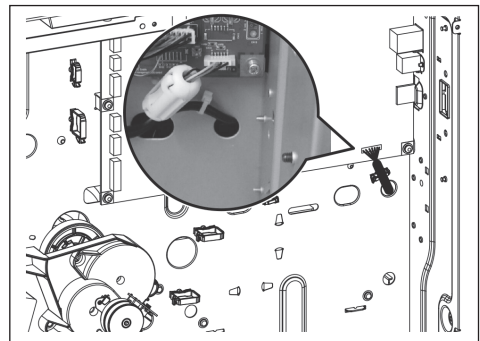

- 13** 기본체의 왼쪽면 커버(나사 6개)를 조립합니다.

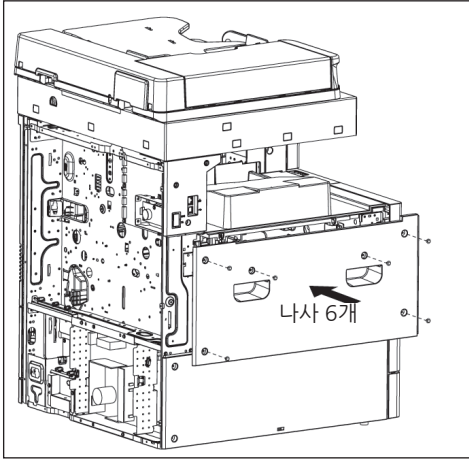

- 14** 본체의 뒷커버(나사 14개)를 조립합니다.

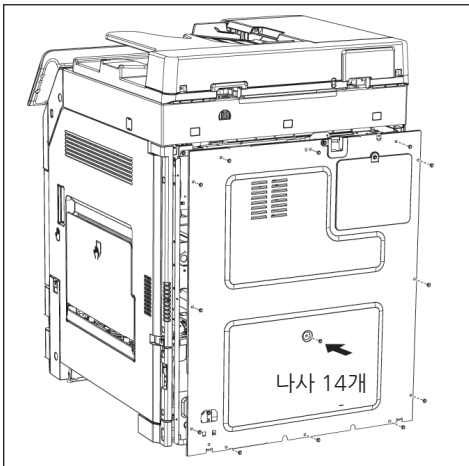

### 3. Wifi 설정하기

- 1** 기기에 전원 코드를 연결하고 전원을 켜 주십시오.
- 2** 서비스모드 화면을 띄워 주십시오.  
(서비스모드에 들어가는 자세한 방법은 서비스 매뉴얼을 참고하시기 바랍니다.)
- 3** “System 2”→“Option”→“Wifi module”을 선택해 주십시오.

- 4** “on/off module”을 선택하고 ON 버튼을 누른 후 [SAVE]를 눌러 주십시오.
- 5** [HOME] 키를 눌러서 서비스 모드에서 나옵니다.
- 6** 기기의 전원을 껐다가 다시 켜 주십시오.

#### 노트

- 화면에 서비스 모드 스크린이 표시 되었을 때는 서비스 모드에서 나온 후 전원을 꺼 주십시오. 10초 이상을 기다린 후에 전원을 다시 켜 주십시오.

### 4. Wifi 설정 확인하기



- 1** 서비스모드 화면을 띄워 주십시오.  
(서비스모드에 들어가는 자세한 방법은 서비스 매뉴얼을 참고하시기 바랍니다.)
- 2** “System 2”→“Option”→“Wifi module”을 선택해 주십시오
- 3** “Check installed”를 선택 후 “Execute”를 눌러 주십시오.
- 4** Value가 on으로 되는 것을 확인하십시오.
- 5** [HOME] 키를 눌러서 서비스 모드에서 나옵니다.

# N620WN

## Wifi安装装置/Wifi Kit安装顺序书

适用产品:N620 Series

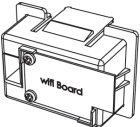
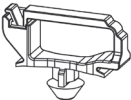
### 1. 附件

No.	名称	图示	数量
1.	Wifi 模块		1
2.	线夹		2
3.	电线		1

\* 根据销售区域不同, 可能有小量的变动。

### 警告



开封后, 去掉包装纸, 并放置在儿童触及不到的地方。  
请勿将头放置在塑料袋中, 可引起窒息危险。



### 备注

- 虽然安装顺序书内包含对于同封品和机器相关的说明, 但是安装顺序书中的照片与实物可能会有细微的差异。这种情况下, 利用已有的实物代替安装顺序书中的照片, 按照安装顺序来进行作业。  
不会引起大的变动或问题。

### 2. 安装步骤

- 1 关闭机器电源, 并取下电源线。
- 2 打开选配部件的箱子, 请确认部品的种类和数量有无异常。
- 3 Wifi模块(1号部品)和电线(3号部品), 如下图所示安装。



- 4 拆下机器的后侧外壳(螺丝14个)。

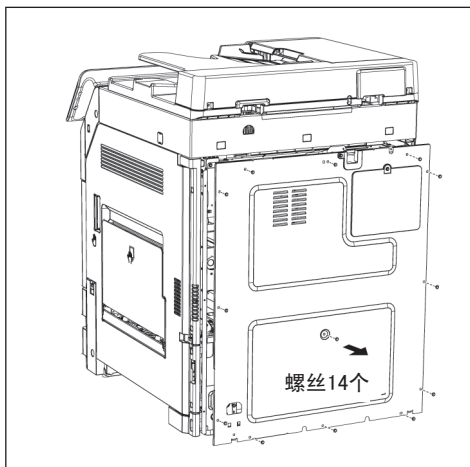

**5** 拆下机器左侧外壳(螺丝6个)。

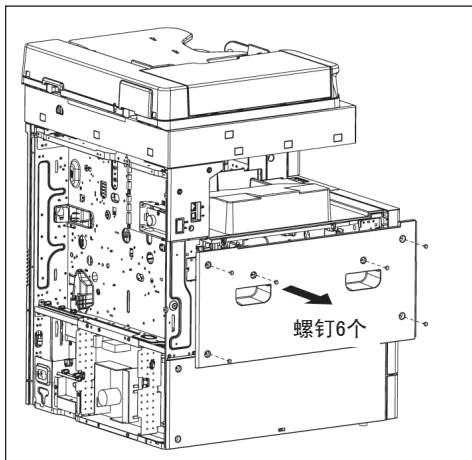

**6** 拆下机器内部的框架(螺丝4个)。

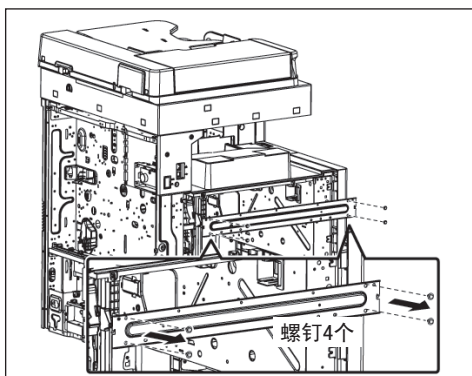

**7** 将第6步中取下的框架内侧面上安装3个线夹。(2号部品, 3个)。

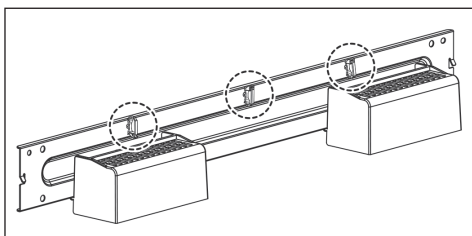

**8** 机器上安装线夹(2个)。

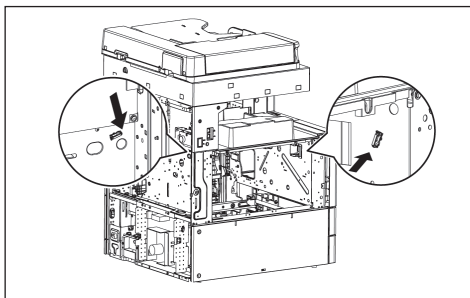

**9** 在机器上安装好Wifi模块后,如图所示,用线夹将其固定。

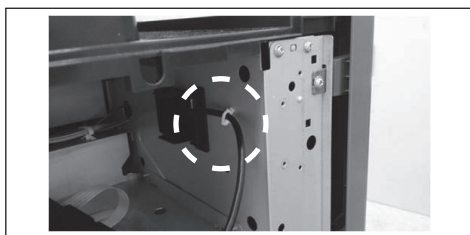

**10** 如图所示,使电线从机器后面的孔里出来。

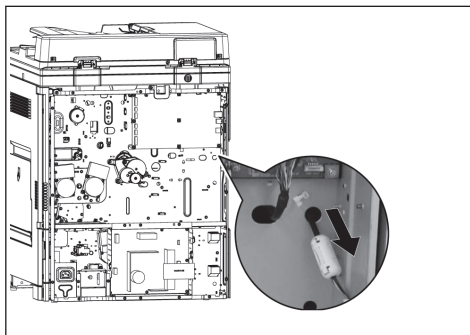

**11** 用第6步中取下的框架上的线夹将Wifi模块的电线收齐后在机器上安装。

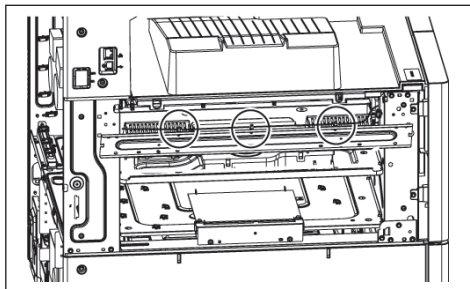

- 12** 使用机器后面的线夹将电线收齐整理后连接到机器主板上。

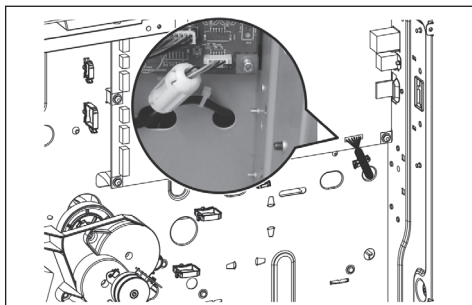

- 13** 安装机器的左侧外壳(螺丝6个)。

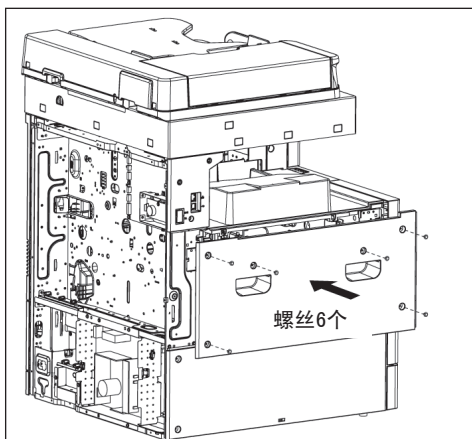

- 14** 安装机器的后侧外壳。(螺丝14个)

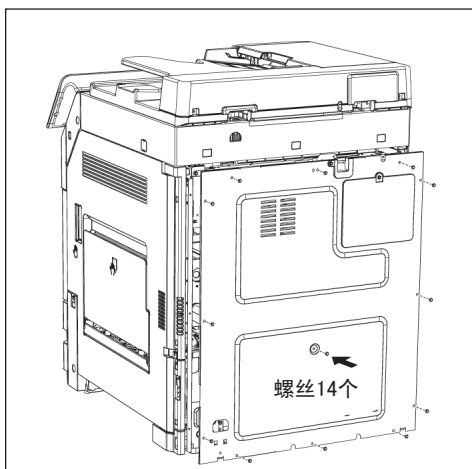

### 3. Wifi的设置

- 1** 连接电源线并打开机器电源。
- 2** 请进入到服务模式的画面。(进入服务模式的详细方法请参照服务手册。)
- 3** 请依次选择“System 2”→“Option”→“Wifi module”。
- 4** 选择“on/off module”,点击 on按键后,点击[SAVE]。
- 5** 点击HOME键,退出服务模式。
- 6** 关闭机器电源并重启。

#### 备注

- 画面中显示服务模式屏幕时,从服务模式中退出后,关闭电源。请等待10秒以上,重新打开电源。

### 4. Wifi设置确认



- 1** 请进入到服务模式的画面。(进入服务模式的详细方法请参照服务手册。)
- 2** 请依次选择“System 2”→“Option”→“Wifi module”。
- 3** 选择“Check installed”后,按下“Execute”。
- 4** 请确认Value处在打开的状态下。
- 5** 点击HOME键,退出服务模式。

# N620WN

## Wifi Installation Device/ Wifi Kit Installation Guide

For : N620 Series

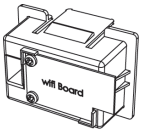
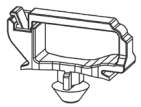
### 1. Accessories enclosed

No.	Description	Shape	Quantity
1.	Wifi module		1
2.	Clamp		5
3.	Cable		1

\* Subject to change depending on the area of sales.

### Warning



After unpacking, remove wrappings and keep them out of the reach of children. Do not place the plastic bag over your head; it may cause suffocation.

### Note

- This installation guide includes descriptions of the accessories enclosed and the device but the photos included may not look same as actual figures. In this case, use the parts described in the installation guide rather than referring to photo images to follow and finish the installation procedure with no difficulty.

### 2. Installation procedure

- 1 Turn the power off and unplug the power cord.
- 2 Unpack the option box and check if there are any accessories missing or broken.
- 3 Assemble the Wifi module (#1 part) and the cable (#3 part) together as in the figure.

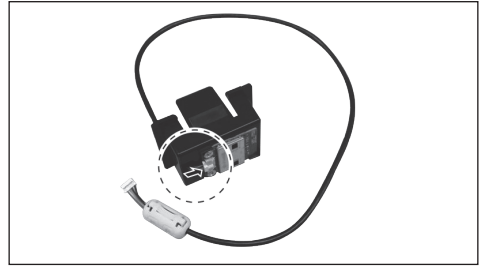

- 4 Unfasten 14 bolts to remove the rear cover from the device.

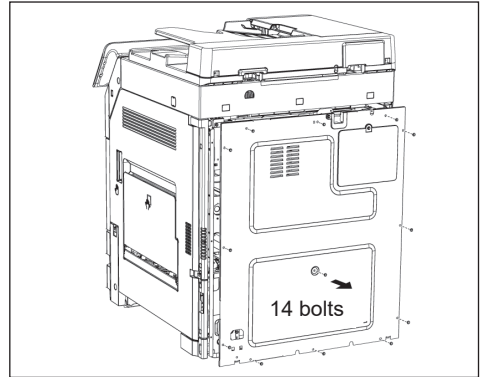

- 5 Unfasten 6 bolts to remove the left cover from the device.

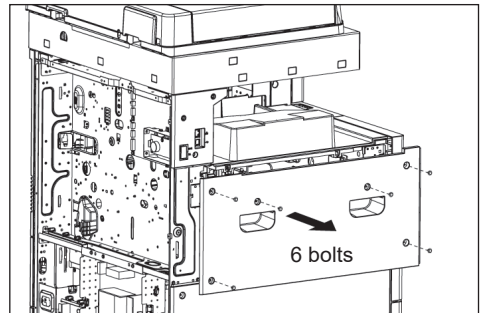



- 6** Unfasten 4 bolts to remove the interior frame from the device.

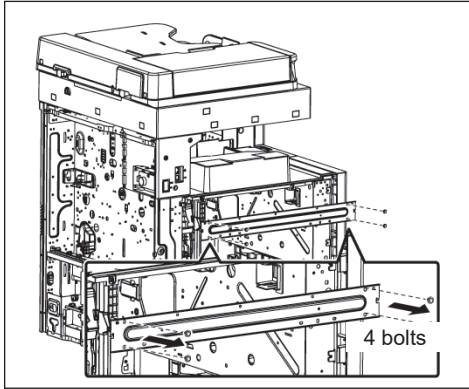

- 7** Install 3 clamps (#2 part) into the frame interior separated in step **6**.

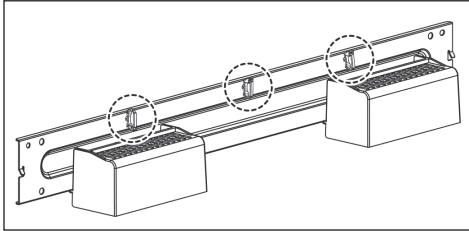

- 8** Install 2 clamps into the device.

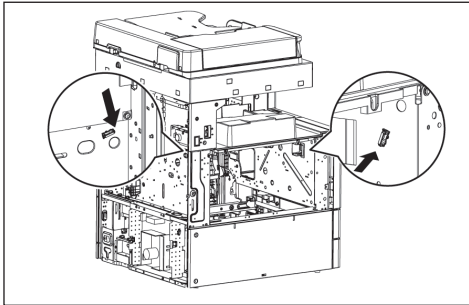

- 9** Install the Wifi module into the device and use the clamp to secure it as in the figure.



- 10** Insert the cable through the hole as in the figure so that the cable comes out to the rear of the device.

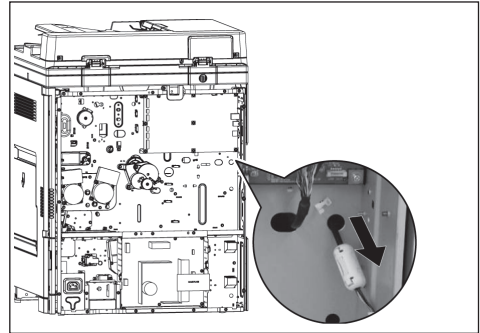

- 11** Connect the cable of Wifi module with the clamp from step **6** and assemble it into the device.

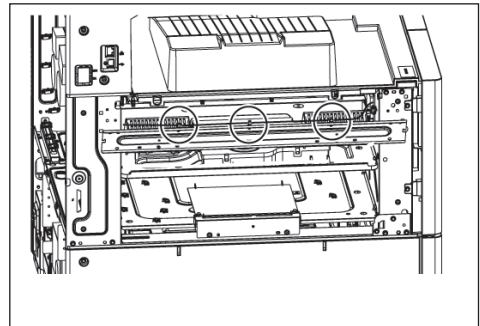

- 12** Use the rear clamp to connect the cable and device board.

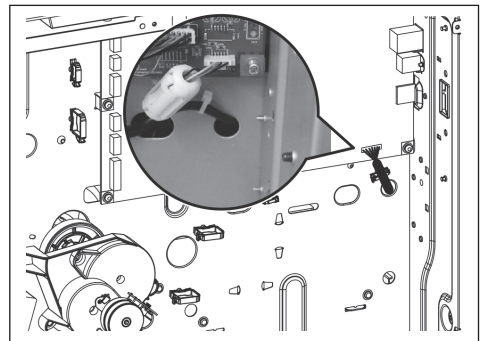

- 13 Fasten 6 bolts to secure the left cover back to the device.

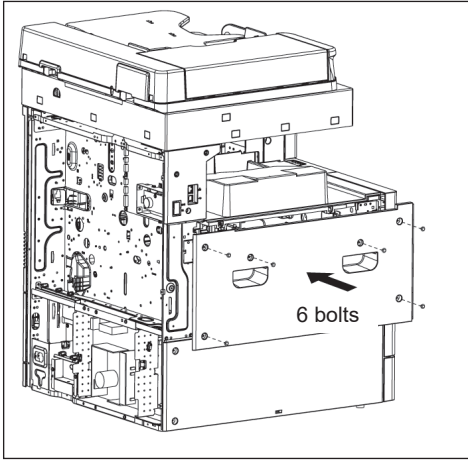

- 14 Fasten 14 bolts to assemble the rear cover back to the device.

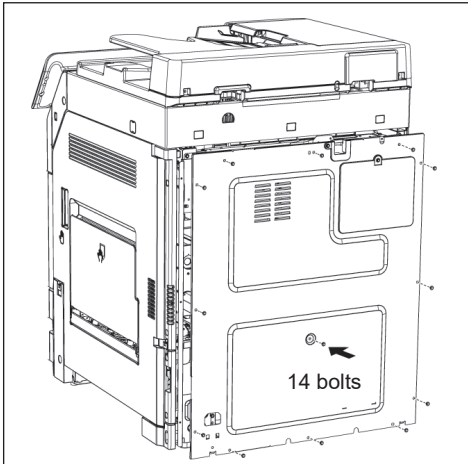

### 3. Set up Wifi

- 1 Plug the device to power source cord and turn power on.
- 2 Open the service mode screen.  
(See the service manual to find how to enter the service mode.)
- 3 Select "**System 2**" → "**Option**" → "**Wifi module**".

- 4 Select "**on/off module**" and press the On button, then [**SAVE**].

- 5 Select the [**HOME**] key to exit the service mode.

- 6 Turn off the power and turn it back on.

#### Note

- When you see the service mode screen, exit from the service mode first to turn off the power. Wait 10 seconds or longer before turning the power on.

### 4. Check Wifi Setting

- 1 Open the service mode screen.  
(See the service manual to find how to enter the service mode.)
- 2 Select "**System 2**" → "**Option**" → "**Wifi module**".
- 3 Select "**Check installed**", then "**Execute**".
- 4 Check if the value becomes "**On**".
- 5 Select the [**HOME**] key to exit the service mode.

■ Memo

