

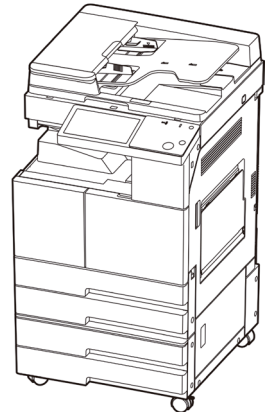

N410/N610/N620/MF Series

A3 Paper Feed Unit 설치 수순서
A3 Paper Feed Unit 设置顺序书
How to Install A3 Paper Feed Unit





A3 Paper Feed Unit 설치 수순서

적용 제품 : N410, N610, N620 Series

1. 액세서리 점검

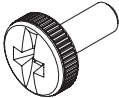
다음 목록과 액세서리의 수량 및 상태를 점검해 주십시오.

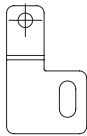
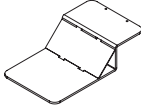
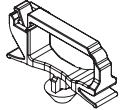
No.	이름	모양	수량
1.	Bolt M4X10		6
2.	Bolt M3X6		2
3.	연결 Bracket		2
4	Safety Part		2
5	Clamp		1

⚠ 경고

- 설치하시기 전에 본체 전원 코드의 플러그를 뽑아 주십시오.
- 유닛 설치에 A3 Paper Feed Unit와 복합기에 대한 교육을 받은 서비스 직원이 직접 설치해 주십시오.

2. 설치 절차

● 본체와 연결하는 방법

- 1 Tape를 제거 하고 모든 Tape 및 포장재가 제거 되었는지 다시 확인해 주십시오.

⚠ 주의

- 썬기 부품 [A]를 제거하십시오.
제거 방법: Jam Door을 열고 Jam Door를 잡은 후 썬기의 끝단을 당기시면 됩니다.
썬기 [A]의 위치는 아래의 그림을 참고해 주십시오.

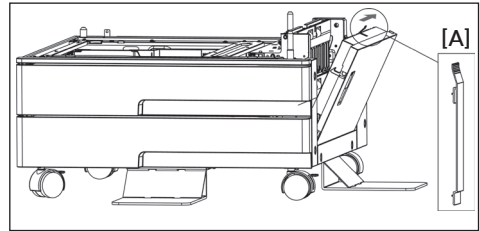

⚠ 경고

- 복합기를 A3 Paper Feed Unit에 세트하기 전에 전원 코드의 안전성을 다시 확인해야 합니다.
만약에 전원 코드 파손이나 고장이면 A3 Paper Feed Unit가 정상적으로 동작하지 않을 수 있습니다.

- 2 A3 Paper Feed Unit의 Tray [B]/[C]를 제거해 주십시오. (Tray 제거시 Side Fence를 A5용지 위치로 조정후 빼내 주십시오.)

- 3 A3 Paper Feed Unit 전/우 측에 Safety Part [D] 2개를 세트해 주십시오.

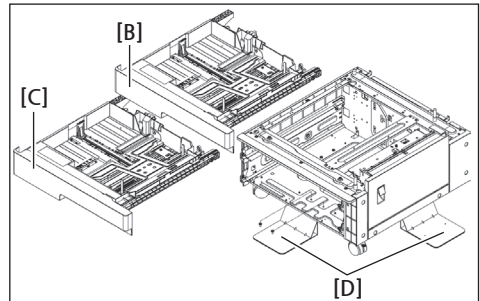

- 4** A3 Paper Feed Unit의 저판에 Safety Part를 Bolt [E](부품1) 4개로 고정해 주십시오.(Bolt 조립시 hole을 볼 수 있게 Safety Part 위치 조정함)

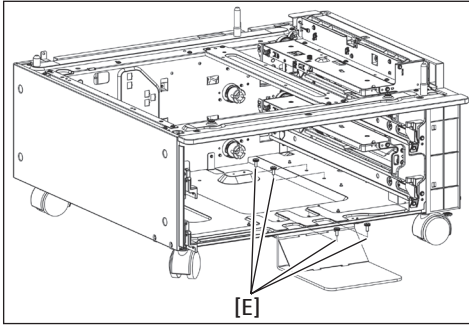

- 5** A3 Paper Feed Unit의 Tray [B]/[C]를 다시 세트해 주십시오.(Tray 세트시 Side Fence를 A5용지 위치로 조정후 세트해 주십시오.)

- 6** 복합기를 A3 Paper Feed Unit에 세트해 주십시오.

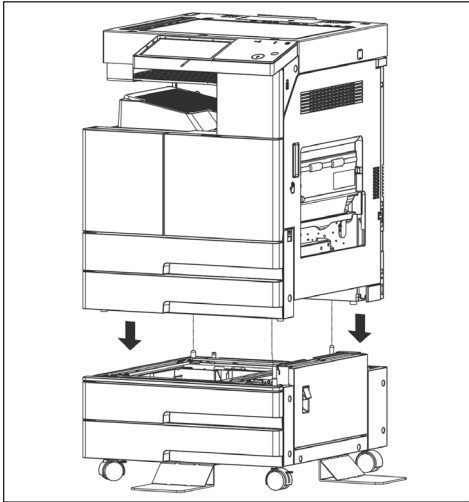

- 7** 복합기의 2단 Tray [F]를 제거해 주십시오.
(Tray 제거시 Side Fence를 A5용지 위치로 조정후 빼내 주십시오.)

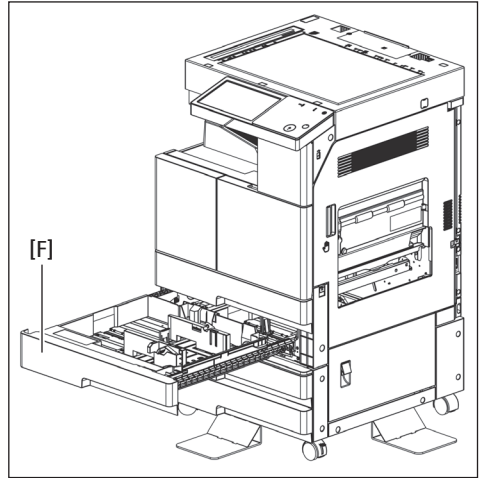

- 8** A3 Paper Feed Unit를 2개의 Bolt [E](부품1)로 고정시켜 주십시오.

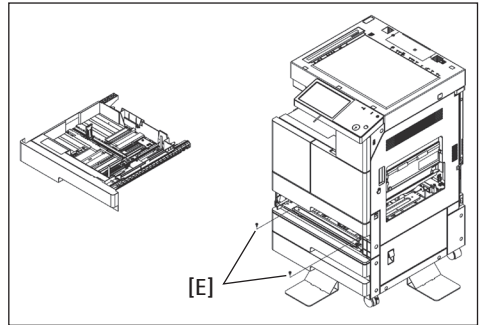

- 9** 복합기의 2단 Tray를 다시 세트해 주십시오.
(Tray 세트시 Side Fence를 A5용지 위치로 조정 후 세트해 주십시오.)

- 10** 복합기의 후측 Cover [G](Bolt 14개)를 제거해 주십시오.

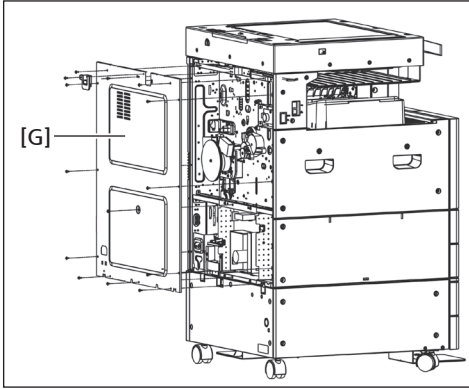

- 11** 표시된 그림대로 케이블 [H]를 복합기의 Connector와 연결해 주십시오. 그리고 Clamp (I)를 본체 Frame에 설치한 다음에 [H]를 고정해 주십시오.

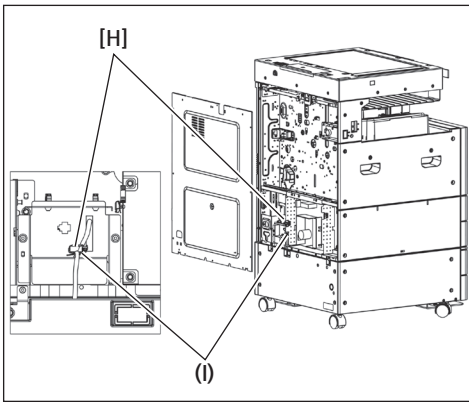

- 12** 복합기의 후측 Cover [G]를 다시 세트해 주십시오.(Bolt 12개 조립)(2개 Bolt (P)는 연결 Bracket [K]을 고정시 사용함)

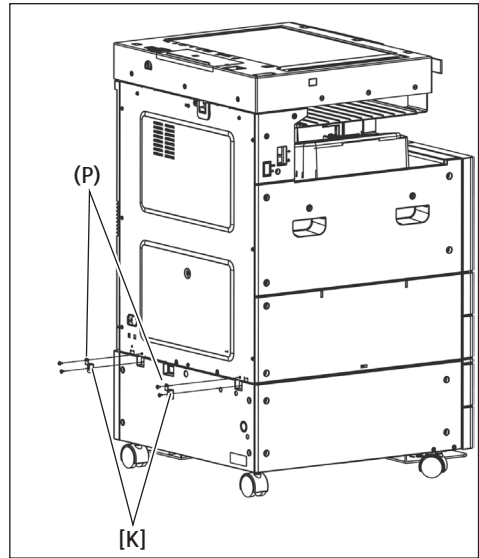

- 13** 연결 Bracket [K]를 좌/우측에 각각 장착해 주십시오.(Bolt 각 2개)

- 14** 용지를 용지 Tray에 넣고 메인 스위치를 켜 주십시오.

- 15** 시스템의 작동과 복사 품질을 점검해 주십시오.

A3 Paper Feed Unit 设置顺序书

适用产品: N410, N610, N620 Series

1. 同封品清点

请参照以下目录清点同封品的数量和状态。

No.	名称	图示	数量
1.	螺丝 M4×10		6
2.	螺丝 M3×6		2
3.	连接铁片		2
4.	安全部件		2
5.	线夹		1

⚠ 警告

- 组装前请将本体的电源插头拔掉。
- 请让接受过A3 Paper Feed Unit和复合机相关教育的服务人员进行安装。

2. 设置顺序

● 与本体的连接方法

- 1 请拆除胶带后再次确认所有胶带及包装材料是否已经全部拆除。

⚠ 注意

- 请拆除掉楔子部品[A]。
拆除方法: 打开Jam Door, 扶住Jam Door并拽动楔子的端部将其取出。
楔子部品[A]的位置请参考下图。

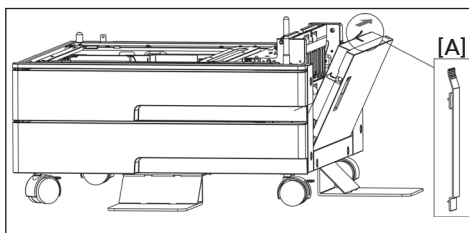

⚠ 警告

- 将复合机向A3 Paper Feed Unit上设置前请务必再次确认电源线的安全性。一旦电源线发生破损或故障, 可能会导致A3 Paper Feed Unit无法正常工作。

- 2 请将A3 Paper Feed Unit的 Tray[B]/[C]拆除。(Tray 拆除时请将Side Fence调整至A5用纸的位置后再进行拆除)

- 3 请将A3 Paper Feed Unit前、右侧的2个安全部件[D]设置好。

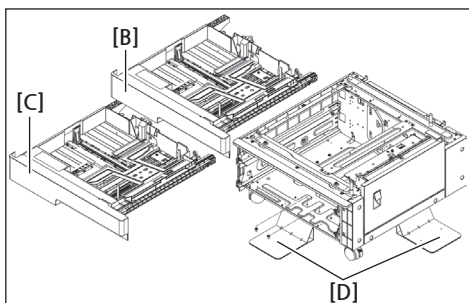

- 4** 请将A3 Paper Feed Unit底板上的安全部件用4个螺丝[E] (部品1) 固定好。(螺丝组装时可以调整安全部件的位置使得螺丝孔对正)

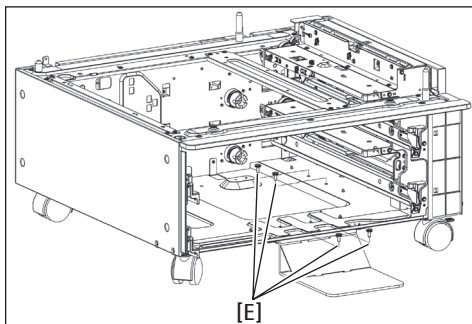

- 5** 请将A3 Paper Feed Unit的 Tray[B]/[C]重新设置。(Tray 设置时请将Side Fence调整至 A5 用纸的位置再进行设置)

- 6** 请将复合机设置在 A3 Paper Feed Unit上。

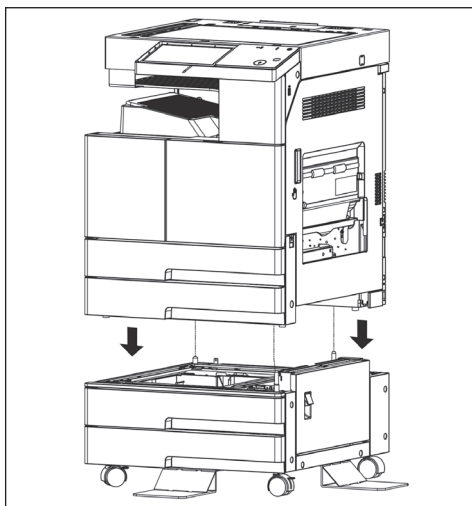

- 7** 请将复合机的2段 Tray[F] 拆除。(Tray 拆除时请将Side Fence调整至 A5用纸的位置后再进行拆除)

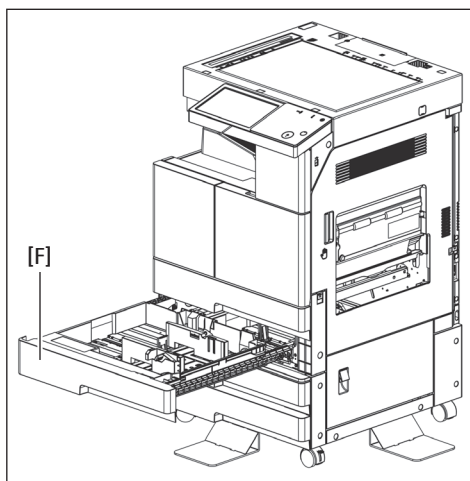

- 8** 请将A3 Paper Feed Unit通过 2个螺丝[E] 进行固定。

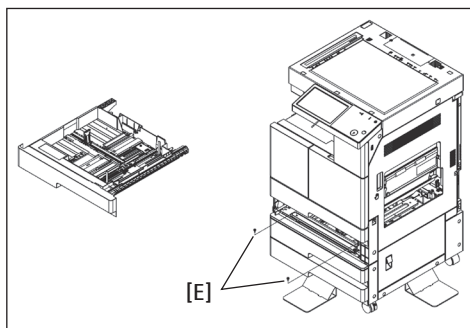

- 9** 请将复合机的2段Tray重新设置好。
(Tray 设置时请将Side Fence调整至A5用纸的位置再进行设置)

- 10** 请将复合机后盖[G] (14个螺丝) 拆除。

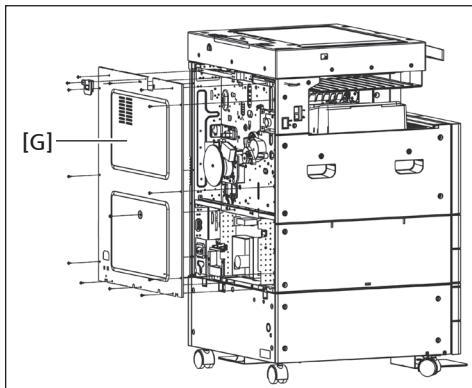

- 11** 如图所示请将电线[H]与复合机的Connector进行连接,然后将线夹(I)设置在主体Frame上,对[H]进行固定。

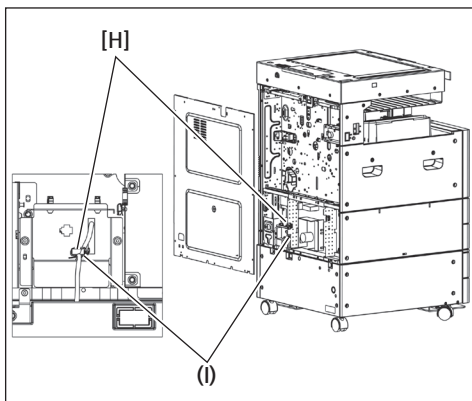

- 12** 请将复合机的后盖[G]重新设置好。(组装12个螺丝(2个螺丝(P)在固定连接铁片[K]时使用))

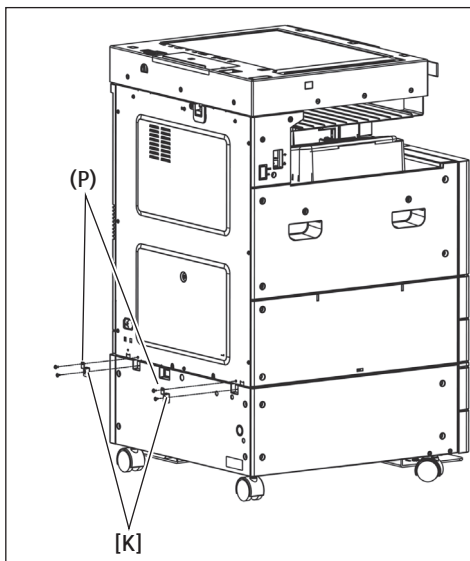

- 13** 请将左右两侧的连接铁片[K]进行安装。(各 2个螺丝)

- 14** 请将用纸放入用纸Tray中并开启主开关。



- 15** 请对系统运转状态及打印品质情况进行确认。

How to Install A3 Paper Feed Unit

Applicable products : N410, N610, N620 Series

1. Check Accessories

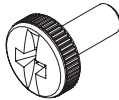
Refer to the following list to check the number of accessories and their conditions.

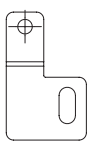
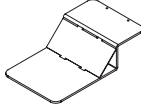
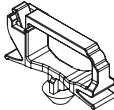
No.	Description	Shape	Quantity
1.	Bolt M4X10		6
2.	Bolt M3X6		2
3.	Connection Bracket		2
4	Safety Part		2
5	Clamp		1

Warning

- **Unplug the main power cord of the device before installation.**
- **It is recommended that the unit is installed by a professional service staff who have been trained for the A3 Paper Feed Unit and MFP.**

2. Installation procedure

• How to connect to the device body

- 1** Remove all tapings and wrappings and make sure they are all removed.

Caution

- **Please remove the wedge [A].**
Removal Method: Open the Jam door and pull the end of the wedge by holding the jam door.
Please refer to the picture below for the position of the wedge.

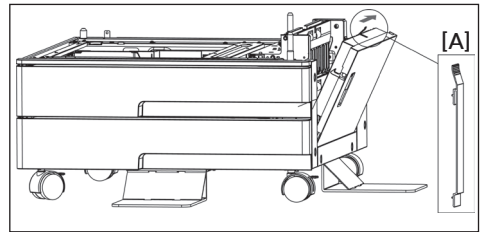

Warning

- **Before setting the MFP onto the A3 Paper Feed Unit, the safety of power cord must be checked.**
If the power cord is damaged or not working, the A3 paper feed unit may not work properly.

- 2** Remove Tray [B] and [C] of the A3 Paper Feed Unit. (When removing the tray, adjust the side fence to the A5 paper position first.)

- 3** Set 2 safety parts [D] on the front and right of the A3 Paper Feed Unit.

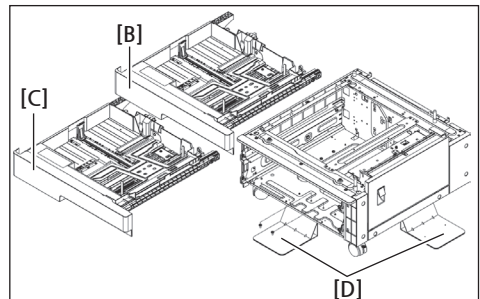

- 4** On the lower part of the A3 Paper Feed Unit, use 4 bolts [E](part1) to secure the safety part.(adjust position of the safety part to make the holes visible when fastening bolts.)

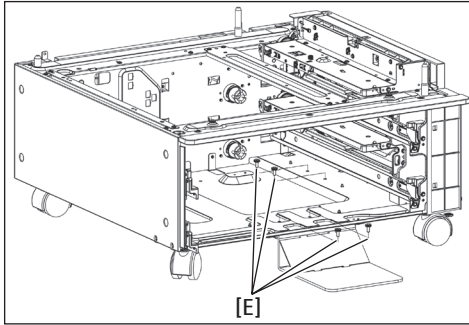

- 5** Place Tray [B] and [C] of the A3 Paper Feed Unit back. (When setting the tray, adjust the side fence to the A5 paper position first.)

- 6** Set the MFP onto the A3 Paper Feed Unit.

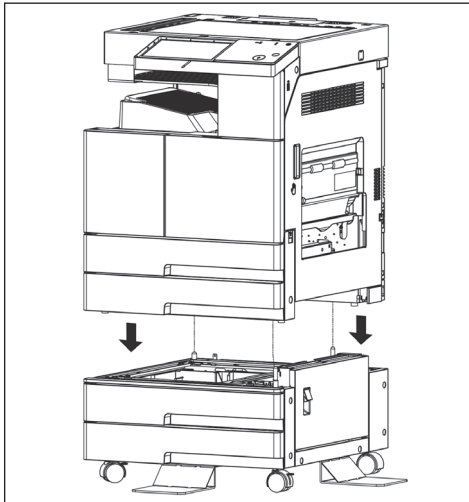

- 7** Remove the upper Tray [F] from the MFP. (When removing the tray, adjust the side fence to the A5 paper position first.)

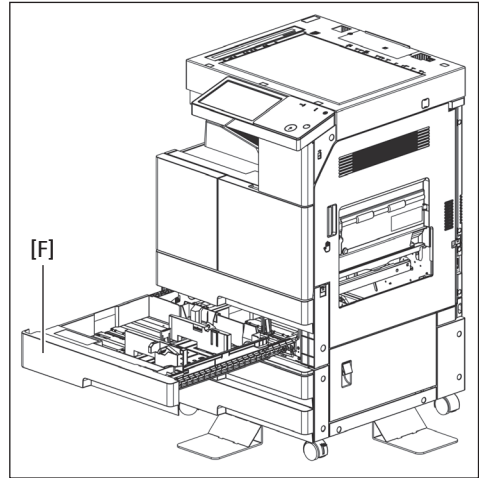

- 8** Use 2 bolts [E] to secure the A3 Paper Feed Unit.

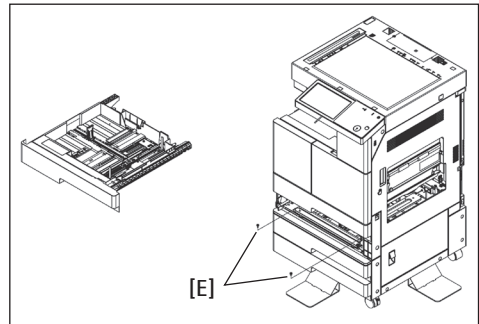

- 9** Place the upper Tray back to the MFP. (When setting the tray, adjust the side fence to the A5 paper position first.)

- 10** Remove the rear cover [G](14 bolts) from the MFP.

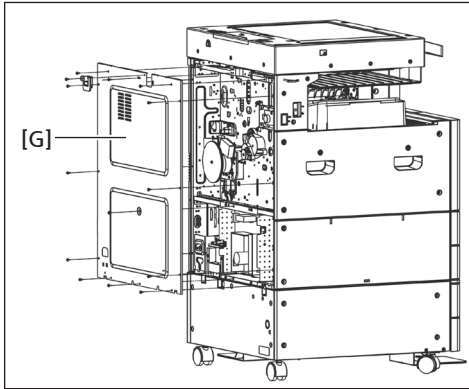

- 11** As in Figure, connect the cable [H] to the connector of the device. Then install clamp (I) into the device frame and fix [H].

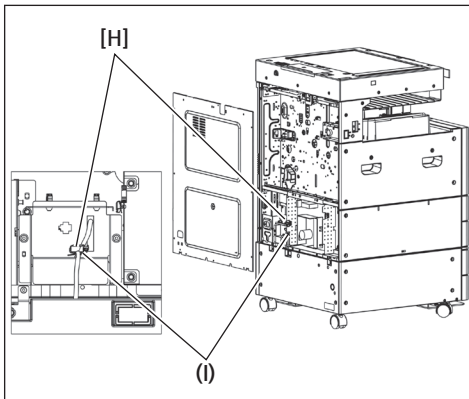

- 12** Fasten 12 bolts to put the rear cover [G] back to the device (use 2 bolts, in (P), to fix the connection bracket [K]).

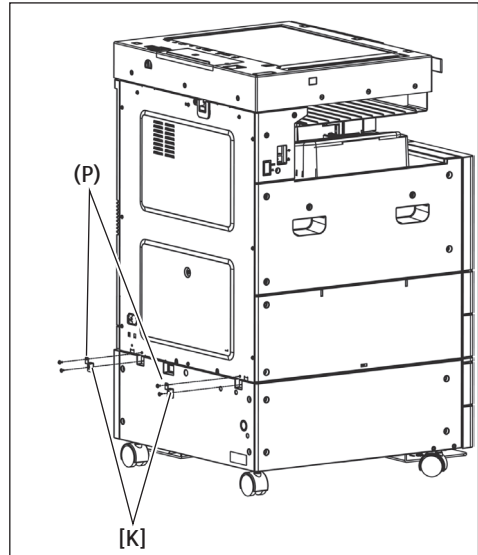

- 13** Fix the connection bracket [K] by using 2 bolts each on right and left.
- 14** Load papers into the paper tray and turn on the main power button.
- 15** Check the quality of print-outs and see if the device works properly.

■ Memo



JSBK9932D
Printed in China